

+



## NEW GENERATION RALLY CAR

MotorSport New Zealand Inc.  
MotorSport House  
102A Kapiti Road, Paraparaumu  
Kapiti Coast 5032  
Phone: +64-4-815-8015  
Email: [technical@motorsport.org.nz](mailto:technical@motorsport.org.nz)  
Website: [www.motorsport.org.nz](http://www.motorsport.org.nz)

# GROUP AP4 PART ONE – PHILOSOPHY AND BUILD PROCESS

### Philosophy

MotorSport New Zealand (MSNZ) have developed these technical regulations for a new generation of 4WD turbocharged rally car eligible for competition in both National and International events within the Asia Pacific region.

The philosophy of AP4 is to establish a set of technical articles that allow rally teams to build locally, or buy cars of parallel design from overseas, that will be of a similar specification and performance to each other and to that of the FIA R5 / S2000 Category cars, but at significantly lower cost. The main focus in developing these technical articles is to allow commercial competitive freedoms in the supply of control parts – which are primarily limited to only those parts deemed to affect performance, reliability and safety – while ensuring sufficient control exists to equalise performance and prevent unnecessarily wasteful development. The build process should be flexible enough to accommodate the specific requirements and skills of individual teams without compromising the quality standards necessary at this level of competition.

Providing an opportunity for local construction and component supply has the potential to insulate competitors from fluctuations in international exchange rates, enables lower inventory costs and shorter delivery times. Having multiple vehicles with many 'common' components also allows teams to reduce their spares inventory. When combined with regional acceptance of the category, these are powerful incentives to build a car compliant with these specifications.

Component parts fall into 4 categories; being **series parts**, **free parts**, **control parts** and **control design parts**, all of which are defined in PART TWO of these regulations.

Part One (herein under) provides an outline of the steps involved in 'building' (or obtaining) an AP4 Rally Car, Part Two provides the specific technical regulations for an AP4 Rally Car and Part Three lists the 'approved constructors/parties' involved and listings of the mandatory 'control parts' necessary to build an AP4 Rally Car.

## **Build Process**

An AP4 Rally Car may be built in New Zealand or Australia to the specifications detailed in PART TWO of these regulations or purchased in part or as a complete car (refer below). Cars built locally are subject to the bodyshell platform and safety cage being fabricated by an 'approved constructor' and common 'control parts' being supplied through the nominated companies as detailed in PART THREE of these regulations. Simplistically, the build process is as follows;

**STEP 1:** Study PART TWO of these regulations, then choose your desired Make & Model of car. Factors to consider here will be the availability / cost of a donor car, adaptability to the regulations and compatibility with the dimensions of the control suspension towers and subframes, engine type suitability / availability and installation orientation. Additionally, the availability of a suitable body-kit or whether a kit will have to be created needs to be considered.

**STEP 2:** Contact the Technical Department of your ASN [MSNZ] to confirm acceptance of the make / model of car as well as your proposed engine type.

**STEP 3:** Decide upon which of the 'approved constructors' (detailed in PART THREE) you wish to use. From here you will discuss with them directly, the mandatory modification / fabrication work (which must be entrusted with them) as well as any, or all, of the other work necessary to complete the car build. Apart from the dimensionally controlled bodyshell / safety cage fabrication work, the rest of the build can be performed by any competent party using the 'control parts' as specified.

**STEP 4:** Upon completion of the AP4 bodyshell (by an 'approved constructor') an inspection must be requested from the ASN [MSNZ] prior to any further work being undertaken. Upon inspection and subsequent validation (of the bodyshell) a Logbook / Passport and Safety Cage Homologation will be issued by the ASN in conjunction with the attachment of an ID plate. From here the final detail and painting of the bodyshell including the fitment of the body kit may progress.

**STEP 5:** The fitment of the ID plate acknowledges the creation of an AP4 rally car and from here the build process (assembly work) may continue in full compliance with PART TWO of the regulations, using the mandatory 'control parts', series parts and/or free parts as prescribed. Any inquiries or guidance sought at this point should be directed to the ASN [MSNZ].

**STEP 6:** Upon completion, the car will be subject to a final safety and eligibility inspection by the ASN [MSNZ] from which point and upon acceptance the car will become eligible for competition.

**Alternatively** a 'Maxi Rally' car (being a car in compliance with the 2013 Specific Regulations for "Maxi Rally" Vehicles – Rallies), may be purchased directly from the constructor in Argentina or through their approved agent as detailed in PART THREE of these regulations. A 'Maxi Rally' car may also be purchased in 'kit form' and assembled in compliance with the stated regulations. Such cars (provided they maintain compliance with these regulations) will be accepted as meeting the eligibility criteria of Group AP4.

**IMPORTANT NOTE 1:** Approval of a proposed make / model of car as well as that of the proposed series engine **MUST** be sought from the ASN [MSNZ] prior to the commencement of build.

**IMPORTANT NOTE 2:** During the build process, the prescriptions of FIA Appendix J article 253 Safety Equipment shall be followed explicitly, unless detailed otherwise in PART TWO of these Technical Regulations.

**Amendment Table**

<b>Amendment Number</b>	<b>Issue/Effective Date</b>	<b>Article reference</b>	<b>Subject / Notes</b>
GRP AP4-22-T001	02/09/2022	2.2, 2.3,9.0	Allowing 3-cylinder Engines, Clarifying Definition of Control Parts, Allowance of a rear Dual Plane Aerodynamic Device
GRP AP4-22-T002	22/12/2022	707	To allow the use of Aluminum alloy body dampers in line with FIA R5 rally cars.

# GROUP AP4

## PART TWO - TECHNICAL REGULATIONS

AP4 article No. & FIA reference No.	Category of Component Part	REGULATION
Article1.0		<b>Definitions:</b>
		<p><b>GROUP AP4:</b> is a rally category developed for National and Regional competition for forced induction 4 wheel-drive cars. It is based upon the principles of the FIA Group R5 category and is intended to create cars of similar performance, as well as that of the Super 2000 Rallies and Group N (including R4) categories.</p> <p>The concept of the AP4 Rally Car is to produce a build specification / technical regulation that ensures cars can be locally built from locally sourced component parts controlled either directly or indirectly by the ASN [MSNZ] . <u>The overriding intention is to ensure that the build specification is controlled</u> whilst guaranteeing that initial build as well as ongoing maintenance costs are kept within realistic bounds.</p> <p>Manufacturer / Dealer involvement is encouraged with respect to promoting their brand through support of Competitors / Teams in building and campaigning their marque.</p> <p><b>Composite material:</b> means a material commonly known as; Fibreglass, fibre reinforced plastic molded plastic.</p> <p><b>Mass Produced:</b> means a product sourced from an; OE manufacturer or from a large scale production catalogue or from a commercial competition parts catalogue.</p>
Article 1.1		<b>General conditions:</b>

		<p>Any specific inquiry relative to these regulations shall be directed to the ASN [MSNZ].</p> <p><b>These regulations shall be read in conjunction with;</b></p> <ul style="list-style-type: none"> <li>• <b>AP4 - The Build Process (Part One, appended to these regulations), and</b></li> <li>• <b>FIA Appendix J article 253 Safety Equipment -reference current version at;</b>  <a href="http://www.fia.com/sites/default/files/regulation/file/253%20%282015%29.pdf">http://www.fia.com/sites/default/files/regulation/file/253%20%282015%29.pdf</a></li> </ul>
		<p>A national vehicle Logbook / Passport, issued by the ASN [MSNZ] is mandatory. The Logbook / Passport shall be issued upon inspection and approval of the completed AP4 bodyshell [refer article 9.0] and approval of the engine type [refer article 2.2].</p> <p>AP4 cars used in rallies (on open roads) must be legally registered for road use; hence all national road transport legislation must be complied with. For Australia this will require the approval of a relevant State or Territory Rally Vehicle Registration Scheme or similar.</p>
<b>Article 2.0</b>		<b>Homologation:</b>
		<p>The basis of the AP4 Rally Car is a Series Production Vehicle, meaning a vehicle (model) that has been manufactured in a certain number of identical examples using series production methods destined for public road use and available through the normal commercial channels of the manufacturer.</p> <p>Eligible cars (base model) do not necessarily have to appear on the list of FIA homologations issued by the FIA. Technical information and specifications shall be sourced either from the FIA Homologation Form (where the model is homologated) or directly from the car manufacturer for the model concerned.</p> <p><b>Note:</b> <i>Cars [built to and in compliance with these regulations] may be accepted in International Rallies within the Asia Pacific region where authorised by the Regional Rally Sporting Regulations and/or approved by the APRC Secretariat (refer APRC National Vehicle Approval Form).</i></p>
<b>Article 2.1</b>		<b>Eligible cars:</b>
		<p>Large Scale Series Production Touring Cars of;</p> <ul style="list-style-type: none"> <li>- either 2 or 4 door bodyshell configuration,</li> <li>- either left or right-hand drive configuration, and</li> <li>- at least four factory seating positions; according to the dimensions defined under FIA Group A.</li> </ul>
<b>Article 2.2</b>		<b>Eligible engines:</b>

<p><b>SP</b></p>	<p>Either a “Series Production Engine” or the “AP4 Designated Joker Engine” are authorised, under the following conditions:</p> <ol style="list-style-type: none"> <li>1. 3 or 4 cylinder up to a maximum capacity of 1620cm<sup>3</sup> * cm<sup>3</sup> (being 2754 cm<sup>3</sup> with 1.7 forced induction coefficient applied that shall be subject to a minimum car weight of 1230Kg.</li> </ol> <p><b>Note:</b> The bore and/or stroke may be adjusted to achieve the designated 1620 cm<sup>3</sup> capacity.</p> <ol style="list-style-type: none"> <li>2. 4 cylinder up to a maximum capacity of 1820cm<sup>3</sup> (being 3060cm<sup>3</sup> with 1.7 forced induction coefficient applied that shall be subject to a minimum car weight of 1300Kg.</li> </ol> <p><b>Note:</b> The bore and/or stroke may be adjusted to achieve the designated 1820 cm<sup>3</sup> capacity</p> <p>At least 2500 identical engine units must have been produced in 12 consecutive months. It will be possible to count models from another manufacturer, provided that they are equipped with the same engine (strictly identical) and produced in a quantity of at least 5000 units in 12 consecutive months.</p>
	<p>The AP4 designated engine is:</p> <ul style="list-style-type: none"> <li>- Mazda Sky Active 1.6L</li> <li>- The EP6 ‘Prince’ series 1598cc turbocharged engine is accepted under ‘GrandFather’ rights where installed prior to 2020 Season</li> </ul> <p><b>Note1:</b> Under these regulation’s a “Series Production Engine” is defined as; any engine fitted to a (model of car) from that manufacturer that is/has been on sale to the general public and/or an engine fitted to a (model of car) from another manufacturer that utilises the same common construction platform. All engine proposals will be subject to approval through the respective ASN prior to becoming eligible for use under these regulations.</p> <p><b>Note2:</b> The “AP4 Designated Joker Engine” may be utilised as an alternative to the “Series Production Engine” and shall retain its production engine capacity.</p> <p><b>Note3:</b> National Series Regulations may authorise other engines and capacity options.</p>

<b>Article 2.3</b>		<b>Component parts:</b>
	<p><b>SP</b></p> <p><b>CP</b></p> <p><b>CDP</b></p> <p><b>FP</b></p>	<p>Component parts of the car are classified as follows and identified in the column to the left of the applicable article;</p> <ul style="list-style-type: none"> <li>● <b>Series Part;</b> being original parts or replacement parts identical to the original parts as fitted to the car / engine at the time of manufacture or subsequently replaced due to use or accident. All such parts shall be available through the original car manufacturer’s dealer network. All relevant specifications shall be referenced from the manufacturers’ official data or applicable FIA homologation form.</li> </ul> <p><i>Note: A series production engine or the AP4 designated engine shall be classified as a ‘Series Part’.</i></p> <ul style="list-style-type: none"> <li>● <b>Control Part;</b> being parts that are detailed in the control part lists, obtained from the stated control parts supplier and fitted to the car as detailed in these regulations. <del>Such parts may only be modified where specifically authorised in the relevant article concerned</del> Such parts may <b>not</b> be modified <b>in any way</b> unless where specifically authorized in the relevant article concerned. Refer PART THREE for the list of ‘control parts’.</li> </ul> <ul style="list-style-type: none"> <li>● <b>Controlled Design Part;</b> being parts that are controlled relative to an approved design / specification (as detailed under the relevant article) which may be freely sourced. Refer PART THREE for listings of ‘Controlled Design Parts’.</li> </ul> <p><i>Note: Gearboxes listed in Part Three List 3 of these regulations shall be classified as a ‘Control Design Part’.</i></p> <ul style="list-style-type: none"> <li>● <b>Free Part;</b> being parts that may be freely sourced. Such parts may be removed or replaced with another part on condition that the substitute part has no additional function relative to the part it replaces. These parts may have other conditions imposed under these</li> </ul>
<b>Article2.4</b>		<b>Authorised modifications and additions:</b>
		<p>These regulations are written in terms of authorisation therefore any modification and/or addition [to the Series model represented] not expressly authorised hereinafter is prohibited.</p> <p>The limits of the modifications and fittings allowed shall be specified under the appropriate article.</p>
		<p>Apart from these, any part worn through use or accident can only be replaced by a part as specified within these regulations.</p> <p>Nuts, bolts and screws; throughout the car may be replaced by any other nut, bolt or screw and have any kind of locking device (washer, locknut etc.), provided the strength characteristics are equal or greater, or unless specified otherwise.</p>

		<p>The following parts / modifications must be specifically approved under AP4 and detailed in the car's National Logbook / Passport;</p> <ul style="list-style-type: none"> <li>- Safety cage; design and homologation to be approved by the ASN [MSNZ], refer FIA document 'Homologation Regulations for Safety Cages'.</li> <li>- Seat supports and anchorages; design to be approved in conjunction with the safety cage homologation.</li> <li>- Safety harness mounting points; design to be approved in conjunction with the safety cage homologation.</li> <li>- Modifications / lightening of the bodyshell; to be approved in conjunction with the safety cage homologation.</li> </ul>
		<p><b>Materials;</b> notwithstanding the above, the use of magnesium alloy, ceramics and/or titanium alloy is not authorised except in the case of those parts fitted to the series model.</p>
<b>Article 2.5</b>		<b>Minimum weights:</b>
		<p>The minimum weight of the actual car shall be:</p> <ol style="list-style-type: none"> <li>1. For up to 1620cc uncorrected capacity cars 1230 Kg</li> <li>2. For 1620 to 1820cc uncorrected capacity cars 1300 Kg</li> </ol>
		<p>The actual car weight; this is the real weight of the car, with only one spare wheel and neither the driver, nor co-driver, nor their safety equipment (being the helmets and FHR devices of both drivers).</p> <p>When two spare wheels are carried in the car, the second spare wheel must be removed before weighing.</p> <p>The use of ballast is permitted under the conditions provided for in FIA App J Article 252-2.2.</p>



		<p>The minimum weight of the competing car shall be 1390 kg (1460kg for 1620 to 1820cc uncorrected) under the conditions set out below;</p> <p>The competing car weight is the weight of the car as it competes with the crew on-board (driver + co-driver with their safety equipment) and one spare wheel.</p> <p>When two spare wheels are carried in the car, the second spare wheel must be removed before weighing.</p> <p>At no time during the competition may a car weigh less than this minimum weight.</p> <p>In case of a dispute during weighing of the competing car, the driver and codriver as well as their safety equipment will be removed; this includes their helmets and FHR's, and the car will be re-weighed.</p>
--	--	---

Article 3.0		Engine - Specification / Performance controls:
	<p><b>SP</b></p>	<p><b>Engine Specification:</b> The engine manufacturers official data or [where homologated] the FIA homologation data shall be referenced. The engine capacity, including the bore and stroke measurements, shall be detailed in the cars Logbook / Passport.</p> <p>Re-sleeving of the engine block is authorised provided the sleeves have a circular internal section and are concentric with the cylinders, dry or wet and distinct from one another.</p> <p>For the sole purpose of being able to fit the gearbox, as well as some ancillary equipment such as engine mounts, local external machining of the engine block is authorised.</p> <p>Engine fasteners {screws, bolts, studs, nuts etc.} may be changed provided that the replacements are made from ferrous material.</p> <p><b>Engine Performance Controls:</b> Engine performance shall be regulated. This is to be controlled by;</p> <ul style="list-style-type: none"> <li>- Engine (air) restrictor, and/or</li> <li>- Car weight.</li> </ul> <p><b>Note:</b> <i>Vehicle performance shall be aligned to the current FIA Group R5 performance</i></p>

301		<p><b>Engine position and mountings:</b></p>
	<p><b>FP</b></p>	<p>The engine may be orientated in either a longitudinal or transverse position under the following conditions;</p> <ul style="list-style-type: none"> <li>- The engine may be moved in its compartment in relation to the series model although it may not be moved outside of the parameters of the original compartment,</li> <li>- The top 1/3<sup>rd</sup> (section) of the bulkhead shall not be modified / changed in order to accommodate engine placement, save that: <ul style="list-style-type: none"> <li>• Manufacturer installed brackets may be removed; and</li> <li>• Manufacturer molded pressings and forming's may be trimmed or removed no further reward than the predominant plane of the bulkhead panel.</li> </ul> </li> </ul> <p>NOTE: The bulkhead is defined as the panel that extends from the horizontal floor-pan to the bottom of the windscreen aperture. Reference diagram below:</p> <div data-bbox="967 547 1585 858" data-label="Image"> </div> <p>Mountings are a free part hence the number and position is not controlled.</p>
317		<p><b>Piston (complete):</b></p>
	<p><b>SP/ FP</b></p>	<p>The series part is authorised, or a free part is authorised under the following conditions;</p> <ul style="list-style-type: none"> <li>- The minimum permissible weight of a piston (with pin, circlips and rings) is 350 grams.</li> <li>- Each piston must have at least three piston rings with a minimum (singular ring) thickness of 0.95 mm. This excludes the oil control ring set.</li> </ul>

<b>318</b>		<b>Connecting rod:</b>
	<b>SP/FP</b>	The series part is authorised, or a free part is authorised under the following conditions; <ul style="list-style-type: none"> <li>- The minimum permissible weight of a connecting rod (with cap, bolts and bearings) is 450 grams.</li> <li>- Only steel is authorised.</li> <li>- The rod cap (big-end) bolts shall be ferrous.</li> </ul>
<b>319</b>		<b>Crankshaft:</b>
	<b>SP</b>	The series part is authorised or a free part is authorised, in both cases the following conditions shall be respected; <ul style="list-style-type: none"> <li>- The minimum permissible weight of the crankshaft (including pilot bearing) shall 12kg irrespective of the following conditions;</li> <li>- The crankshaft may be subjected to additional mechanical treatment and machining, and</li> <li>- The main and connecting rod bearing journals may be reclaimed respecting the standard width.</li> </ul>
	<b>FP</b>	<ul style="list-style-type: none"> <li>- The width and diameter of each crankshaft journal may be increased.</li> </ul>
<b>320</b>		<b>Flywheel:</b>
	<b>SP/FP</b>	The series part is authorised, or a free part is authorised under the following conditions; <ul style="list-style-type: none"> <li>- The minimum permissible weight of the flywheel (including starter ring and fixing bolts) is 3450 grams,</li> <li>- It must be made in one-piece with the exception of the starter ring,</li> <li>- The starter ring gear must respect a minimum diameter of 240mm, and</li> <li>- Only steel is authorised.</li> </ul>
<b>321</b>		<b>Cylinder head:</b>
	<b>SP</b>	Only the series part is authorised and shall respect the following conditions; <ul style="list-style-type: none"> <li>- The material shall remain standard.</li> <li>- The valve seats as well as the valve guides are free although the respective angles of the valve stems shall not be changed.</li> <li>- The gasket face (plane) may be re-surfaced by a maximum of 1 mm (for adjusting the compression ratio).</li> </ul>
<b>322</b>		<b>Cylinder head gasket:</b>

	<b>FP</b>	The cylinder head gasket may be freely sourced.
<b>324</b>		<b>Injection System:</b>
	<b>SP/FP</b>	The series part (system) is authorised, or a new system may be accepted under the following criteria; <ul style="list-style-type: none"> <li>- The maximum number of injectors shall be equal to the number of cylinders, or the number fitted to the series engine.</li> <li>- A new injector rail of free design is authorised, fitted with threaded connectors for connecting the lines and the fuel pressure regulator.</li> <li>- Any other additional injection system (such as water) is prohibited.</li> </ul>
<b>324 d)</b>		<b>Throttle valve housing:</b>
	<b>SP/FP</b>	The series part (throttle valve housing) is authorised, or a free part is authorised. The following conditions apply; <ul style="list-style-type: none"> <li>- Only a single throttle body is authorised,</li> <li>- The maximum opening size (at the butterfly) is 64 mm +/- 0.25 mm,</li> <li>- The housing may be modified externally but not the diameter of the opening of the butterfly, and</li> <li>- The housing mounting 'bolts' shall be drilled for the possible application of wire seals.</li> </ul>
<b>324 h)</b>		<b>ECU / Sensors / Actuators / Data acquisition:</b>
	<b>SP/FP</b>	The series ECU (system) is authorised, or a freely sourced ECU may be accepted under the following criteria; <ul style="list-style-type: none"> <li>- The ECU is a commercially available system from a recognised manufacturer, and</li> <li>- All actuators must be controlled by the ECU.</li> </ul>
	<b>FP</b>	Wiring looms are free.
<b>325</b>		<b>Camshaft:</b>
	<b>SP/FP</b>	The series part is authorised, or a free part is authorised under the following conditions; <ul style="list-style-type: none"> <li>- The maximum lift for the inlet valves shall be 11 mm,</li> <li>- The maximum lift for the exhaust valves shall be 11 mm, and</li> <li>- The number of camshafts must remain unchanged.</li> </ul>

<b>327</b>		<b>Intake manifold:</b>
	<b>SP/FP</b>	The series part (intake manifold) is authorised, or a free part is authorised. The following conditions apply; <ul style="list-style-type: none"> <li>- In both cases modification to the manifold is unrestricted.</li> </ul>
<b>327</b>		<b>Intake valves:</b>
	<b>SP/FP</b>	The series parts and dimensions shall be retained. Direct replacement valves are authorised provided they respect the same dimensions and are sourced from a recognised manufacturer of valves.
<b>328</b>		<b>Exhaust valves:</b>
	<b>SP/FP</b>	The series parts and dimensions shall be retained. Direct replacement valves are authorised provided they respect the same dimensions and are sourced from a recognised manufacturer of valves.
<b>328</b>		<b>Exhaust manifold:</b>
	<b>SP/FP</b>	The series part (exhaust manifold) is authorised, or a free part is authorised under the following conditions; <ul style="list-style-type: none"> <li>- Only steel, stainless steel or cast iron is authorised.</li> </ul>
<b>328</b>		<b>Exhaust system:</b>
	<b>FP</b>	The exhaust system is free downstream of the turbocharger, provided it respects the following criteria; <ul style="list-style-type: none"> <li>- Fitment does not entail the modification of other components, (except floorpan as per bodyshell approval),</li> <li>- The exit of the exhaust pipe shall be at the rear of the car, and</li> <li>- The noise levels must respect the stated maximum prescribed by the ASN of the country where the car competes.</li> </ul>

<b>329</b>		<b>Balancing shafts:</b>
		If the series engine was fitted with balancing shafts, these may be removed together with their drive system.
<b>330</b>		<b>Ignition:</b>
	<i>SP/FP</i>	The make and type of spark plugs, ignition coils, rev limiter and leads are free.
<b>331</b>		<b>Cooling system:</b>
	<i>SP/FP</i>	The series part ( <b>water pump</b> ) is authorised, or a free part is authorised under the following conditions; <ul style="list-style-type: none"> <li>- The pump is either mechanically or electrically driven, and</li> <li>- The pump is located in the engine compartment.</li> </ul>
	<i>SP/FP</i>	The series part ( <b>water radiator</b> ) is authorised, or a freely sourced part is authorised provided it remains within the engine compartment.
	<i>FP</i>	Coolant hoses may be freely sourced.
	<i>FP</i>	An expansion (header) tank is authorised as are 'air-bleeds'.
<b>333</b>		<b>Lubrication system:</b>
	<i>SP/FP</i>	The series part ( <b>oil sump</b> ) is authorised, or a free part is authorised under the following conditions; <ul style="list-style-type: none"> <li>- It is made from either steel sheet or aluminium,</li> <li>- Its sole function must be that of containing oil.</li> </ul>
	<i>SP/FP</i>	The series part ( <b>oil pump</b> ) is authorised or a free part is authorised under the following conditions; <ul style="list-style-type: none"> <li>- The (oil) pressure regulation system may be modified, and</li> <li>- A system (pressure pipe with fittings from a connection on the engine block, or the cylinder head, to the turbo charger and a reverse pipe from the turbo charger to the oil sump or engine block) to lubricate the turbo may be added.</li> </ul>
	<i>FP</i>	An alternative engine breather system is authorised including the fitment of a supplementary breather tank.  Series emission control equipment may be removed.
<b>334</b>		<b>Turbocharger:</b>

	<b>SP/ FP</b>	The series part is authorised, or a free part is authorised under the following conditions; <ul style="list-style-type: none"> <li>- The turbocharger assembly shall come from a recognised manufacturer of turbochargers (produced in a quantity of at least 2500 units),</li> <li>- The turbocharger must be a single unit, with single stage compression and expansion, and must not have variable pitch or variable geometry.</li> </ul>
	<b>FP</b>	An adapter is authorised between the exhaust manifold and the turbocharger on condition that the thickness of this component is less than 30 mm.
		<b>Turbocharger restrictor:</b>
	<b>FP</b>	For engines up to and including 1620cc – a <b>34 mm restrictor shall be fitted.</b> For engines up to and including 1820cc – a <b>34mm restrictor shall be fitted.</b>  All the air necessary for feeding the engine must pass through this restrictor which shall respect the following specifications; <ul style="list-style-type: none"> <li>- The maximum internal diameter shall be 34 mm maintained for a minimum of 3 mm measured downstream of a plane perpendicular to the rotational axis situated at a maximum of 50 mm upstream of a plane passing through the most upstream extremities of the wheel blades (ref: FIA drawing 254-4).</li> <li>- The diameter shall be complied with irrespective of the temperature conditions.</li> <li>- The external diameter of the restrictor at its narrowest point shall be less than 40 mm which must be maintained over a distance of 5 mm to each side.</li> <li>- The restrictor shall be made from a single material and may be pierced solely for the purpose of mounting and sealing.</li> <li>- Mounting of the restrictor to the turbocharger must be carried out in such a way that two screws have to be entirely removed in order to detach the restrictor from the compressor housing.</li> </ul>
		All restrictors shall be wired for the application of seals by the Scrutineers. The wire must pass through the turbine housing, the compressor body or mounting clamp screw, the compressor body and terminate after (with at least 100 mm of free wire) the two screws retaining the restrictor.
<b>334</b>		<b>Intercooler (air exchanger):</b>



	<b>SP/ FP</b>	<p>The series part is authorised, or a free part is authorised under the following conditions;</p> <ul style="list-style-type: none"> <li>- It is wholly contained within the parameters of the engine compartment and/or immediately forward of the compartment.</li> </ul> <p>External water spray systems are authorised.</p>
<b>Article 4.0</b>		<b>Fuel system:</b>
<b>401</b>	<b>CDP</b>	<p>The <b>fuel tank</b> must come from an FIA-approved manufacturer and be compliant with FIA - FT3-1999, FT3.5 or FT5-1999 minimum specifications. The tank shall have a maximum capacity of 110 litres and the use of safety foam is recommended.</p> <p>The location of the fuel tank and pumps must respect the following conditions;</p> <ul style="list-style-type: none"> <li>- The tank must be situated in the cockpit in the rear seat area,</li> <li>- The floorpan [in the rear seat area] may be modified in order to install the tank; the maximum dimensions of the resulting hole in the floorpan are 1000 x 500 mm and the floorpan longitudinal rails shall not be modified,</li> <li>- The tank must be at least 50 mm behind the obligatory diagonal member in the main rollbar and forward of the rear wheel centreline,</li> <li>- The bottom of the tank must be at least 80 mm from the lowest point of the chassis, and</li> <li>- The pumps must be placed in the tank.</li> </ul>
	<b>CDP</b>	<p>The tank must be contained in a leak-proof box attached to the floorpan. A 1.2 mm thick metallic screen between the tank and the cockpit is compulsory. The height of the assembly in the cockpit (tank + leak-proof box) must not exceed 600 mm. Only two air-tight and fluid-tight inspection hatches (in addition to the inspection hatch for checking the tank's validity date) in the cockpit are allowed.</p> <p>The <b>fuel circuit</b> [to and from the tank] must comprise only the following parts;</p> <ul style="list-style-type: none"> <li>- one fuel supply outlet (to the engine),</li> <li>- optionally one fuel return (into the tank),</li> </ul>
	<b>CDP</b> <b>CDP</b>	<ul style="list-style-type: none"> <li>- two quick-action couplings for refuelling (these couplings must be situated inside the vehicle), and</li> <li>- one breather in conformity with article 253-3.4 of Appendix J.</li> </ul> <p>Series emission control equipment may be removed.</p>

<b>Article 5.0</b>		<b>Electrical System:</b>
<b>501</b>	<i>FP</i>	The <b>battery</b> may be freely sourced and its location is unrestricted although it must be located within the confines of the safety cage structure. The battery shall be of a sealed type if located within the cockpit.
	<i>FP</i>	The series ignition / starter switch may be retained or a new switch may be fitted.
	<i>FP</i>	In all cases, and additional to the series ignition switch, a general circuit-breaker shall be fitted operable from both inside and outside of the car in compliance with Appendix J 253-13. Additionally, it must be able to be operable by both the driver and co-driver (from their normal seated position). It shall disconnect all circuits that keep the engine running which must include the battery, ignition, fuel pump and alternator.
	<i>FP</i>	Wiring looms are free.
<b>502</b>	<i>FP</i>	<b>Alternator;</b> the make and type is free provided it remains driven from the engine crankshaft.
<b>502</b>	<i>FP</i>	<b>Starter motor;</b> the make and type is free.
<b>Article 6.0</b>		<b>Transmission System:</b>
<b>602</b>		<b>Clutch:</b>
	<i>SP/FP</i>	The series parts, or free parts are authorised under the following conditions; <ul style="list-style-type: none"> <li>- it shall have a maximum of 2 friction discs (centre plates), and</li> <li>- if the original diameter is not retained, the minimum diameter of the centre plate/s is 183 mm.</li> </ul>
	<i>FP</i>	Clutch control is free provided it remains foot pedal operated.
<b>603</b>		<b>Gearbox:</b>
	<i>SP/CDP</i>	Either a 'production based' series gearbox from any large scale series production Touring Car is authorised or a 'control design part' gearbox is authorised as detailed in PART THREE List 3 of these regulations.

	<p><b>SP</b></p> <p>For series gearboxes, the following conditions apply;</p> <ul style="list-style-type: none"> <li>- The gearbox type / specification shall be a commercially available unit from a recognised gearbox manufacturer,</li> <li>- A maximum of 6 forward ratios + reverse gear is authorised,</li> <li>- The interior of the gearbox casing is free, meaning the number of teeth and the ratios are not controlled,</li> <li>- The joints of the external gearbox linkage are free, and</li> <li>- The gearbox casing / bolts shall be drilled for the application of wire / seals. The sealing shall concern only the gearbox and shall not prevent maintenance of the clutch and/or associated accessories.</li> </ul> <p><b>CDP</b></p> <p>For 'control design part' gearboxes, the following conditions apply;</p> <ul style="list-style-type: none"> <li>- The specified gearbox shall maintain compliance with the manufacturers specification,</li> <li>- Only parts supplied by the gearbox manufacturer for the specified gearbox shall be used,</li> <li>- The joints of the external gearbox linkage are free, and</li> <li>- The gearbox casing / bolts shall be drilled for the application of wire / seals. The sealing shall concern only the gearbox and shall not prevent maintenance of the clutch and/or associated accessories.</li> </ul>
	<p><b>FP</b></p> <p>Either an 'H' pattern or sequential gear selection control linkage is authorised provided its operation remains solely mechanical. The gear lever shall be fixed on either the floor or the steering column and can be adjustable.</p>
603	<p><b>FP</b></p> <p>For the sole purpose of being able to fit the gearbox (to the engine block), the bell-housing may be modified / adapter plate fitted.</p> <p><b>FP</b></p> <p>The gearbox mountings are a free part, hence the number and position is not controlled.</p> <p><b>FP</b></p> <p>Additional braces between the chassis and gearbox may be added provided this is their sole purpose, to locate the gearbox.</p>
603	<p><b>FP</b></p> <p>Gearbox cooling - an additional oil cooling device is authorised. The lines, pump and activation method are free.</p>

604		<b>Centre differential:</b>
	<b>SP/FP</b>	<p>The series part centre differential or a free part centre differential is authorised under the following conditions;</p> <ul style="list-style-type: none"> <li>- In all cases an active centre differential is not authorized. Where the centre differential/unlocker forms part of the approved transmission these shall remain unmodified. See List 3 Control Parts.</li> </ul>
		<ul style="list-style-type: none"> <li>- Where the series part is used the fitment of an alternative locking device/clutch that locks the front and rear drive outputs together is required. This alternative locking system may release upon the application of the handbrake using only a hydraulic or electrical system connected separately to the handbrake lever, independent of the brake system hydraulics,</li> <li>- The fitment of a mechanical Limited Slip Differential is authorised.</li> </ul>
605		<b>Final-drive and differential:</b>
	<b>SP/FP</b>	<p><b>Final-drive and final-drive housing;</b> a series part shall be sourced or an aftermarket part from a recognised manufacturer. In both cases;</p> <p>The final-drive casing / bolts shall be drilled for the application of wire / seals. The sealing shall concern only the final-drive / differential unit and shall not prevent the removal of the unit from the car.</p>
	<b>FP</b>	Mounts are free provided they utilise the unmodified locations provided on the control rear subframe.
	<b>FP</b>	<p><b>Differential unit;</b> only a mechanical type limited-slip differential [LSD] is authorised under the following conditions;</p> <ul style="list-style-type: none"> <li>- Its origin is free provided that it can fit inside the unmodified housing.</li> </ul>
	<b>FP</b>	An oil cooling device for the rear differential is authorised. Lines, pump and activation method are free.
606		<b>Transverse and longitudinal transmission shafts:</b>

	<b>SP/FP</b>	<p><b>Transverse driveshafts:</b> a series part may be freely sourced, or a custom driveshaft manufactured to industry standards by a specialist company utilising series components is authorised. The following conditions apply;</p> <ul style="list-style-type: none"> <li>- The material of the shaft shall be ferrous, and</li> <li>- The constant velocity (CV) joints must be matched to the control part hub carrier / bearing assembly.</li> </ul>
	<b>SP/FP</b>	<p><b>Longitudinal driveshaft;</b> a series part maybe freely sourced, or a custom driveshaft manufactured to industry standards by a specialist company is authorised. In the latter case the following conditions apply;</p>
		<ul style="list-style-type: none"> <li>- A minimum weight of complete shaft (including centre bearing mount) of 8.75 kg, or both sections of a 2 piece driveshaft, and</li> <li>- The material of the shaft shall be ferrous.</li> </ul>
<b>Article 7.0</b>		<b>SUSPENSION SYSTEM:</b>
<b>700</b>	<b>CP</b>	<b>Upper suspension (mounting) points;</b> are controlled both front and rear by the ‘control part’ turrets installed on the bodyshell by the approved constructor (refer article 9.0).
<b>700</b>	<b>FP</b>	<p><b>Front and rear upper plate;</b> may be freely sourced provided its sole purpose is to locate the top of the shock absorber (damper) to the bodyshell ‘control part’ turret. The following conditions apply;</p> <ul style="list-style-type: none"> <li>- Only aluminium or steel is authorised,</li> <li>- The shock absorber shaft (top) shall be positioned within a 10mm radius of the centre of the turret structure., and</li> <li>- The only provision for adjustment shall be through rotating the suspension upper plate within the turret.</li> </ul>
<b>700</b>		<p>Maximum wheel track shall be:</p> <ul style="list-style-type: none"> <li>– Front 1863mm measured on the axle vertical centre-line at the lowest point of the rim outer edge</li> <li>– Rear 1855mm measured on the axle vertical centre-line at the lowest point on the rim outer edge</li> </ul>
<b>701</b>	<b>CP</b> <b>CDP</b>	<p><b>Front and rear hub carrier / bearing assemblies;</b> are ‘control parts’ and shall be directly fitted to the ‘control part’ upright. The following conditions apply;</p> <ul style="list-style-type: none"> <li>- The hub bearing assemblies are series parts, hence direct replacement units of identical specification are authorised.</li> </ul>

701	<b>CP</b>	<p><b>Front and rear uprights;</b> are ‘control parts’ and shall not be modified in any way shape or form. They shall be directly fitted to the ‘control part’ wishbones (adapter) and the shock absorber housing.</p> <p><b>Note:</b> Each upright unit incorporates the following provisions;</p> <ul style="list-style-type: none"> <li>- Attachment point (lower) for the suspension wishbone (adapter).</li> <li>- Attachment point (upper) for the shock absorber unit.</li> <li>- Attachment point for the steering arm (bracket).</li> <li>- Attachment point for the rear toe link.</li> <li>- Attachment point for the brake caliper (bracket).</li> <li>- Attachment point for the hub-carrier / bearing assembly.</li> </ul>
701	<b>CP</b>	<p><b>Front and rear lower wishbones;</b> these are ‘control parts’. They shall be directly fitted to the ‘control part’ subframes and the ‘control part’ uprights. The only permissible modification is the addition of a protective strip along the leading edge of the rear lower wishbones to prevent gravel damage.</p> <p>The following conditions apply;</p>
	<b>CDP</b>	<ul style="list-style-type: none"> <li>- The rod end (bearings) may be replaced with direct replacements of the same specification.</li> </ul> <p>The only adjustments possible are those provided for by the ‘control parts’.</p>

701	<b>CP</b>	<p><b>Front and Rear Subframes:</b> these are ‘control supplied’ parts and shall not be modified in any way shape or form other than as permitted below:</p> <ul style="list-style-type: none"> <li>- The sub-frame front support brace may be individually created to suit each individual chassis configuration</li> <li>- Attachment points for the driveshaft safety hoop are authorised on the front sub-frame</li> <li>- Attachment points for mounting of the steering rack are authorized on the front sub-frame (either Mitsubishi or Woodward design)</li> <li>- Attachment points for mounting undercar protection are authorized on both the front and rear sub-frames</li> </ul> <p><b>Front subframe;</b> shall be installed to the mounting points on the bodyshell as fabricated by the approved constructor under the conditions prescribed - refer article 9.0. The following options apply;</p> <ul style="list-style-type: none"> <li>- Option 1 Front subframe – for longitudinal engine / gearbox installation [refer control parts list], or</li> <li>- Option 2 Front subframe - for transverse engine / gearbox installation being either Sadev or Xtrac design[refer control parts list].</li> </ul> <p>For all options, the following applies;</p> <ul style="list-style-type: none"> <li>- The front subframe mountings, including suspension attachments may not be modified.</li> </ul> <p>The frame must remain detachable from the bodyshell, and</p> <ul style="list-style-type: none"> <li>- A minimum weight of 8.8 kg applies (bare subframe).</li> <li>- It is permissible to use the Control Part subframe mounting kit as supplied by the Control Parts Supplier to complete installation of the front subframe in the bodyshell.</li> </ul> <p><b>Rear subframe;</b> shall be installed to the mounting points on the bodyshell as fabricated by the approved constructor under the conditions prescribed - refer article 9.0. The following options apply;</p> <ul style="list-style-type: none"> <li>- Rear subframe for Sadev rear differential, and</li> <li>- Rear subframe for X-Trac rear differential</li> </ul> <p>For both options the following applies:</p> <ul style="list-style-type: none"> <li>- The rear subframe mountings, including suspension attachments may not be modified.</li> <li>- The subframe must remain detachable from the bodyshell, and</li> <li>- A minimum weight of <u>8.5 kg</u> applies (bare subframe).</li> </ul>
-----	-----------	---

706	<b>FP</b>	<p><b>Front and rear anti-roll bars systems;</b> are free respecting the following conditions;</p> <ul style="list-style-type: none"> <li>- The bars shall be made from ferrous material,</li> <li>- The bars shall not be adjustable from the cockpit, and</li> <li>- The bar links maybe freely sourced.</li> </ul>
707	<b>FP</b>	<p><b>Front and rear shock absorbers (dampers) / springs;</b> are free respecting the following conditions;</p> <ul style="list-style-type: none"> <li>- Only McPherson type shock absorbers / spring assemblies are authorised for the front and rear suspension which must be of a commercially available mass-produced (ferrous or Aluminum alloy) type from a recognised suspension components manufacturer,</li> <li>- Only shock absorber / spring assemblies that fit within the unmodified 'control part' bodyshell turret are authorised, and</li> <li>- Only plain bearings are authorised hence linear bearing type dampers are specifically prohibited.</li> </ul>
700		<p><b>Electronic stability control systems;</b> if originally fitted shall be removed in their entirety.</p>
<b>Article 8.0</b>		<b>Braking system:</b>
803	<b>FP</b>	<p><b>An alternative hydraulic circuit is authorised to that fitted to the series model, provided the following conditions are respected;</b></p> <ul style="list-style-type: none"> <li>- All [brake system] components shall comply with national road transport legalisation / regulations.</li> </ul> <p>ABS systems shall be removed in their entirety.</p>
803	<b>SP/FP</b>          <b>FP</b>	<p><b>Pedal assembly / pressure regulator; either the series parts, or free parts are authorised provided the following conditions are respected;</b></p> <ul style="list-style-type: none"> <li>- A pedal box assembly is authorised provided it is of a commercially available mass-produced type from a recognised brake components manufacturer,</li> <li>- The assembly may be adjustable in relation to its connection to the bodyshell.</li> </ul> <p>Pressure regulator / limiter; is authorised either as part of a pedal box assembly or as a separate hydraulic valve, the location of which is free. All parts must come from a large scale production catalogue or from a competition parts catalogue.</p>



803	SP/FP	<p><b>Master cylinders; either the series parts, or free parts are authorised provided the following conditions are respected;</b></p> <ul style="list-style-type: none"> <li>- The make and type of master cylinder is free provided it is of a commercially available mass-produced type from a recognised brake components manufacturer.</li> </ul> <p>All parts must come from a large-scale production catalogue or from a competition parts catalogue.</p>
803	SP/FP	<p><b>Servo-brake; either the series parts, or free parts are authorised provided the following conditions are respected;</b></p> <ul style="list-style-type: none"> <li>- The make and type of servo unit is free provided it is of a commercially available mass-produced type from a recognised brake components manufacturer, or</li> <li>- The series unit may be removed.</li> </ul>
803	FP	<p><b>Gravel specification - Front calipers; are free as to make and design provided the following conditions are respected;</b></p> <ul style="list-style-type: none"> <li>- Calipers must be commercially available mass-produced parts from a recognised brake components manufacturer,</li> <li>- Only one caliper unit per wheel is authorised,</li> <li>- Only steel or aluminium is authorised for the caliper housing/body, and</li> <li>- Maximum of 4 pistons per caliper.</li> </ul> <p>All parts must come from a large scale production catalogue or from a competition parts catalogue, except the mounting brackets which may be freely sourced.</p> <p>Titanium and ceramic material is specifically prohibited.</p> <p><b>Tarmac specification – Front calipers; TBA</b></p>

	<p><b>FP</b></p>	<p><b>Gravel Specification - Rear calipers;</b> are free as to make and design provided the following conditions are respected;</p> <ul style="list-style-type: none"> <li>- Calipers must be commercially available mass-produced parts from a recognised brake components manufacturer,</li> <li>- Only one caliper unit per wheel is authorised,</li> <li>- Only steel or aluminium is authorised for the caliper housing/body, and</li> <li>- Maximum of 4 pistons per caliper.</li> </ul> <p>All parts must come from a large-scale production catalogue or from a competition parts catalogue, except the mounting brackets which may be freely sourced.</p> <p>Titanium and ceramic material is specifically prohibited.</p> <p><b>Tarmac specification – Rear calipers;</b> TBA</p>
<p><b>803</b></p>	<p><b>CDP/FP</b></p>	<p><b>Gravel specification - Front discs / mounting bells;</b> are free as to make and design provided the following conditions are respected;</p> <ul style="list-style-type: none"> <li>- One-piece Series parts are authorised.</li> <li>- Discs (rotors) and mounting bells (hats) must be commercially available mass-produced parts from a recognised brake components manufacturer.</li> <li>- Maximum diameter of 304 mm / minimum nominal thickness of 28 mm. Manufacturers recommended wear limits must be respected.</li> <li>- Cooling ducts may be added provided that the air must be drawn from the front bumper assembly</li> </ul> <p>All parts must come from a large scale production catalogue or from a competition parts catalogue.</p> <p><b>Tarmac specification – Rear discs / mounting bells;</b> TBA</p>

803	<b>CDP/FP</b>	<p><b>Gravel specification - Rear discs / mounting bells;</b> are free as to make and design provided the following conditions are respected;</p> <ul style="list-style-type: none"> <li>- One-piece Series parts are authorised.</li> <li>- Discs and mounting bells (hats) must be commercially available mass-produced parts from a recognised brake components manufacturer.</li> <li>- Maximum diameter of 304 mm / minimum nominal thickness of 25.4 mm. Manufacturers recommended wear limits must be respected.</li> </ul> <p>- Cooling ducts may be added provided that the intakes are separate to the bodywork Parts come must be either a CDP part or from a large scale production catalogue or from a competition parts catalogue.</p>
		<b>Tarmac specification – Rear discs / mounting bells; TBA</b>
803	<b>FP</b>	<b>Handbrake assembly;</b> the series mechanical handbrake may be replaced with a hydraulic system.

Article 8.1	Steering system:	
804	<b>FP</b>	<b>Steering wheel;</b> free as to make and design provided it is a commercially available part. A quick-release coupling (wheel to column) is authorised.
	<b>FP</b>	<b>Steering column;</b> free as to design and mounting provided the sum of its parts are of Series origin and/or commercially available mass-produced parts from a recognised steering components manufacturer.
	Any column adjusting system must be locked and must be operated only with the use of tools.	
	Any steering lock system shall be removed.	
	<b>SP/FP</b>	<b>Steering rack assembly (housing / rack / rods and rod ends);</b> shall be in compliance with the following provisions; <ul style="list-style-type: none"> <li>- The origin of all parts shall be either, Series parts, or commercially available parts mass-produced by a recognised steering components manufacturer,</li> <li>- The rack shall be mounted on the ‘control part’ front subframe at the locations provided,</li> <li>- It is authorised to modify or add rack bar supports on both ends of the casing, and</li> <li>- It is authorised to modify the rack casing for the sole purpose of fixing to the subframe.</li> </ul>
	<b>FP</b>	<b>Power assistance;</b> is authorised, either hydraulic or electric provided the parts are from a series production car or are commercially available mass-produced units from a recognised steering components manufacturer.
<b>FP</b>	<b>Steering cooling device;</b> is authorised and may be freely sourced.  <b>Bulkhead / firewall opening;</b> New positions and a new openings may be introduced for the steering column and the gear-shift linkage.	

<b>Article 8.2</b>		<b>Wheels and tyres:</b>		
805	FP	<p>Wheel rim design: Make is free and dimensional specifications are controlled as follows:</p> <table border="0" style="width: 100%;"> <tr> <td style="width: 40%; text-align: center;">Gravel specification</td> <td style="width: 60%;">Diameter: 15 inch Width: up to 7 inch</td> </tr> </table>	Gravel specification	Diameter: 15 inch Width: up to 7 inch
		Gravel specification	Diameter: 15 inch Width: up to 7 inch	
<table border="0" style="width: 100%;"> <tr> <td style="width: 40%; text-align: center;">Tarmac specification</td> <td style="width: 60%;">Diameter: TBA Width: TBA</td> </tr> </table>	Tarmac specification	Diameter: TBA Width: TBA		
Tarmac specification	Diameter: TBA Width: TBA			
<b>Article 9.0</b>		<b>Bodyshell – General conditions:</b>		
900	CP	<p>The foundation of the AP4 Rally Car is the <u>uniform build specification of the bodyshell which includes common suspension geometry (mounting points) in conjunction with the installation of the safety cage</u>, therefore the modification / fabrication of the Series Production (donor vehicle) bodyshell shall only be performed by an ‘Approved Constructor’ or by another party under the approval / supervision of the ASN MSNZ Technical Dept].</p> <p>The client shall supply the ‘Approved Constructor’ with their Series Production bodyshell;</p> <p>The ‘Approved Constructor’ shall perform the following modifications utilizing an approved ‘AP4 bodyshell jig’ or dimensional specifications (as appropriate);</p> <ul style="list-style-type: none"> <li>- Installation of the ‘control part’ front and rear suspension turrets,</li> <li>- Fabrication / installation of the front and rear subframe mounting points,</li> <li>- Fabrication / installation of the safety cage and associated reinforcements.</li> </ul> <p>The ‘Approved Constructor’ may perform, (or may delegate another party to perform) the following required modifications to the Series Production bodyshell;</p> <ul style="list-style-type: none"> <li>- Fabrication and installation of the leak-proof box for the fuel tank (refer article 4.0),</li> <li>- Fabrication of the transmission tunnel to accommodate the drive-line and transmission,</li> <li>- Modifications to accommodate the drive-shaft and suspension elements,</li> </ul>		

		<ul style="list-style-type: none"> <li>- Modification (removal) of the spare wheel housing in the rear floor,</li> <li>- Modifications to enable fitment of the engine / transmission and ancillary components,</li> <li>- Local modification of the shell to facilitate fitment of the body kit, and</li> <li>- Removal of any unused brackets, accessory supports and trims.</li> </ul> <p>All the additional mounting points on the series bodyshell must be reinforced so that, under all circumstances, they can withstand the loads caused by the modifications to the suspension, independently of the safety cage.</p> <hr/> <p>New front and rear inner wheel arches shall be fabricated that attach to the 'control part' suspension towers and extend laterally to meet the (widened) guards.</p> <p>However, within the context of the freedom of the wheel arch, it is permitted to partially cut the upper side rail at the level of the wheel arch. This cut-out side rail must be reconstructed in such a way as to ensure that the resistance of the car in case of impact is at least equal to the original resistance. The outer wheel arches may be modified in order to house the wheels authorised.</p> <p>The chassis front lower side rail may be modified to allow fitment of the gearbox assembly and for the passage of driveshafts. The modified side rail must be reconstructed in such a way as to ensure that the resistance of the car in case of impact is at least equal to the original resistance. Localised modifications of the bodyshell are authorised for removing unused accessory supports and trim.</p> <p>The weight of an AP4 bodyshell thus modified shall weigh no less than 310Kg. For the purpose of establishing this weight the bodyshell comprises the following; Series production unibody shell, safety cage, competition seat mounts fixed to the shell, safety fuel tank box complete with lid, front and rear suspension turrets, front and rear sub-frame mounts, steering column lower mount, front and rear sway bar mounts and tunnel modifications for the drivetrain. Not included are: rear hatch, front guards, front and rear bumper assemblies, doors and glazing.</p> <p>The chassis front and rear lower side rails may be modified to allow fitment of an anti-roll bar.</p> <p>Each completed AP4 bodyshell shall be subject to inspection and approval by the ASN [MSNZ] Technical Dept prior to a Logbook / Passport being issued and an ID plate being attached.</p>
--	--	---

		<b>Doors:</b>
	<i>SP</i>	The series doors (front and rear) may be modified, solely for the following reasons; <ul style="list-style-type: none"> <li>- To enable the fitment of <b>energy absorbing foam</b>, the interior part of the door frame may be modified including the removal of any series intrusion beams.</li> <li>- Localised modification of the rear doors is authorised to allow the passage of the wheel.</li> </ul>
	<i>FP</i>	Interior door trim panels shall be fitted, the design being free.  Any central door-locking system shall be removed.
		<b>Lateral side protection:</b>
	<i>CDP</i>	Lateral side protection is mandatory when polycarbonate windows are installed. A minimum volume of 60L of energy absorbing foam shall be fitted in each front door. The type of foam shall respect the FIA specification and have a minimum density of 58 g/l.
		<b>Jacking / Stand support points:</b>
	<i>FP</i>	Jacking points may be added, strengthened and/or moved in the bodyshell sill panels.
		<b>Transmission tunnel / central floor pan:</b>
	<i>CDP</i>	The central transmission tunnel / floor may be modified. The dimensions of the fabricated tunnel must be sufficient only to allow the passage of the transmission and the exhaust line.  The minimum thickness of all the steel sheet replacing the original steel sheet is 1.2 mm.
		<b>Rear floor pan:</b>
	<i>CDP</i>	The rear part of the interior floor may be modified by removing the spare wheel housing and adding a plane steel sheet with some beading reinforcements in its place.  The minimum thickness of all the steel sheet replacing the original steel sheet is 1.2 mm.

		<b>Safety cage:</b>
	<i>CP</i>	<p>The safety cage shall be installed by the ‘approved constructor’ or where specifically requested and authorised by the ASN [MSNZ] by another recognised constructor.</p> <p>The safety cage must be homologated by the ASN [MSNZ] which is a fundamental part of the bodyshell approval.</p> <p>The safety cage shall not be modified or changed in any way, shape or form from the design homologated and as detailed in the cars Logbook / Passport.</p>
		<b>Body-kit:</b>
	<i>CDP</i>	<p>A body-kit shall be created / obtained, the design of which must be approved by the ASN [MSNZ]. The body-kit shall comprise of the following parts which shall be shown ( <sup>3</sup>/<sub>4</sub> front and <sup>3</sup>/<sub>4</sub> rear photos) in the cars Logbook / Passport;</p> <ul style="list-style-type: none"> <li>- Front bumper</li> <li>- Rear bumper</li> <li>- Front guards (LH and RH)</li> <li>- Rear guards (LH and RH) including rear door extensions</li> <li>- Side skirts</li> <li>- Rear aerodynamic device (rear spoiler / wing assembly)</li> </ul>
	<i>CDP</i>	<p><b>Front bumper;</b> The basic shape of the series front bumper (central section) must be retained, although the following is authorised;</p> <ul style="list-style-type: none"> <li>- The bumper may be widened in order to align with widening of the front guards,</li> <li>- The series grille may be replaced with wire mesh,</li> <li>- Additional openings may be made in the bumper together with the side elements of the front wings, but the total surface of openings in the protective molding must be no more than 2500 cm<sup>2</sup>. The openings must not affect the structural integrity of the bumper,</li> <li>- The material shall be that of the series part and/or a composite material,</li> <li>- The minimum weight of the front bumper is 4.5 kg (except if the original bumper is kept),</li> <li>- The lower part of the front bumper may be detachable. No element of this detachable part may be more than 100 mm in height and protrude beyond the upper part, when seen in vertical projection, and</li> <li>- New fastenings may be created to enable ease of removal / replacement.</li> <li>- No additional aerodynamic elements are authorized.</li> </ul> <p>It is permitted to remove the original mounting / crash protection parts situated between the series bumper and the bodyshell.</p>



	<b>CDP</b>	<p><b>Rear bumper;</b> The basic shape of the series rear bumper (central section) must be retained, although the following is authorised;</p> <ul style="list-style-type: none"> <li>- The bumper may be widened in order to align with widening of the rear guards,</li> <li>- The material shall be that of the series part and/or a composite material,</li> <li>- Replacement of series removable decorative features with a flat surface forming an integral part of the rear bumper,</li> <li>- A modification of the original cut-out for the exhaust, or to create a 100 cm<sup>2</sup> cut-out, is authorised, and</li> <li>- New fastenings may be created to enable ease of removal / replacement.</li> </ul>
	<b>CDP</b>	<p><b>Front guards;</b> The basic shape of the front guards (upper section) must be retained, although the following is authorised;</p>
	<b>CDP</b>	<ul style="list-style-type: none"> <li>- The guard may be widened in-line with the wider wheel-track of the car. This increase may be obtained by means of an extension or a new part may be created.</li> <li>- The material shall be that of the series part and/or a <b>composite material</b>,</li> <li>- The maximum width between the guards is 1820 mm (measured on the front axle centre-line),</li> <li>- No additional air intakes or outlets are authorised, and</li> <li>- Additional aerodynamic elements are not authorised.</li> </ul> <p><b>Rear guards;</b> The basic shape of the rear guards (upper section) must be retained, although the following is authorised;</p> <ul style="list-style-type: none"> <li>- The guard may be widened in-line with the wider wheel-track of the car. This increase may be obtained by means of an extension or a new part may be created.</li> <li>- The material shall be that of the series part and/or a composite material,</li> </ul> <p>General conditions; the guards must cover the whole of the complete wheel in radial projection; this means that the upper part of the wheel/tyre assembly, located vertically over the wheel hub centre, must be covered by the bodywork when measured vertically.</p> <p><b>Side skirts;</b> of free design are authorised provided they follow the shape of the original bodywork and are contained within a line drawn between the front and rear guard width. Side skirts must be a single plane with no aerodynamic elements.</p>
		<p><b>Rear aerodynamic device:</b></p>

**SP/CDP**

The series part may be retained or replaced with an alternative device respecting the following conditions;

A single plane device is authorised which must be made in one single piece (a single profile and no adjustment flap) and must conform to the road use legislation in the country in which the vehicle is registered.

- The device must be rigid and offer no possibility for the penetration of air (groove, hole, slot, opening, etc.).
- The device must be totally contained within the frontal projection of the car (excluding any side mirrors).
- The side plates may extend beyond 110 cm, when seen from the front, but must not generate any aerodynamic force.
- The wing will be checked with the car horizontal.
- The device must be contained within the vertical projection of the car perimeter excluding mirrors. (refer also to Article 900, Body Kit approval by ASN)
- With the exception of the supports, it must be made from fiberglass or molded plastic.
- The wing must respect the dimensions detailed below and must be able to fit into the box at Figure 2

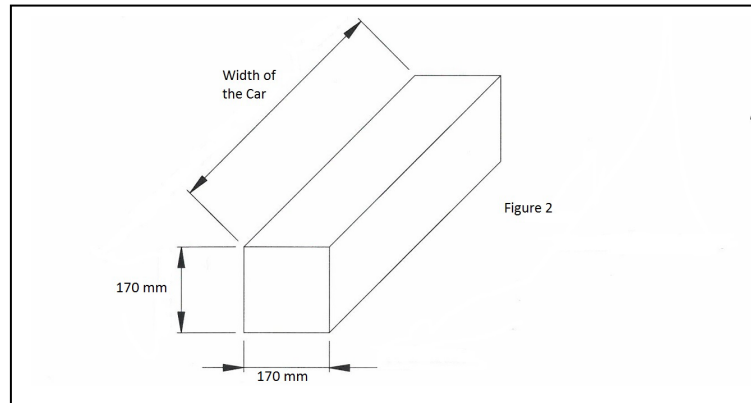

**Alternatively** a dual plane device is authorized and must conform to New Zealand Traffic Regulations.

- The device must be rigid and offer no possibility for the penetration of air (grooves, holes, slots, opening etc.)
- The device must have only two horizontal elements
- The device shall have no more than five vertical elements including end mounts
- The device must be contained within the frontal projection of the car

		<ul style="list-style-type: none"> <li>- All devices must extend no further rearward than 200mm behind the rear bumper (refer also to Article 900, Body Kit approval by ASN)</li> <li>- The wing compliance will be checked with the car horizontal</li> <li>- The device must be made from fibre-glass, molded plastic or carbon fibre.</li> </ul> <p><b>Note:</b> A minimum weight for rear aero devices is under consideration for introduction in 2020.</p>
		<b>Other panels:</b>
	<b>SP/CDP</b>	The series <b>bonnet</b> or a composite replica is authorised. In both cases it may be internally modified to enable fitment of the engine / engine ancillaries.
	<b>SP/CDP</b>	<p>Cut-outs may be introduced under the following conditions;</p> <ul style="list-style-type: none"> <li>- They respect a maximum surface area of 1000 cm<sup>2</sup></li> <li>- They have fine mesh fitted.</li> <li>- A plastic part serving as trim may be added of maximum height in relation to the bonnet being 15 mm.</li> </ul> <p>The series <b>boot lid / tail gate</b> or a composite replica is authorised.</p>
		<b>Front upper cross-member (radiator support):</b>
	<b>SP/FP</b>	The upper front cross-member may be modified (between the headlamps of the car) to enable fitment of the engine / engine ancillaries provided this does not affect the rigidity of the chassis structure. Additionally, the cross-member may be replaced with a different support.
<b>901</b>		<b>Bodyshell – Interior:</b>
		All of the series model (aesthetic) <b>interior trim</b> shall be removed including carpets and sound-deadening materials. Manufacturer installed safety belts and SRS equipment shall be removed
		<b>Front and rear bulkheads:</b>
	<b>FP</b>	For 2 and 3 volume cars the front bulkhead must provide an air-tight and fluid-tight seal between the engine and interior. For 3 volume cars, additionally a rear (boot compartment) bulkhead may be fitted.
<b>901</b>		<b>Dashboard / Instruments:</b>

	<p><b>SP</b></p> <p>The series dashboard may be modified [but not replaced] although the general shape and appearance of the original must remain unchanged.</p> <p>The anchorage points may be modified / added to for the sole purpose of installing the safety cage.</p> <p>The trim situated below the dashboard and which is not a part of it may be removed.</p> <p><b>SP/FP</b></p> <p>The series instruments are authorised, or instruments may be freely sourced provided 'on-road' (Warrant of Fitness) compliance is maintained.</p> <p><b>FP</b></p> <p>Supplementary panels for instruments and/or switches are authorised.</p>
<b>901</b>	<b>Heating / Air conditioning system :</b>
	<p><b>SP/FP</b></p> <p>The series heating / AC system may be removed in which case an electric demist system or similar system must be retained. <i>Note: An effective method of demisting the windscreen must be maintained.</i></p>
<b>902</b>	<b>Front windscreen and wiper mechanism:</b>
	<p><b>SP/FP</b></p> <p>The series windscreen is authorised or a commercially available replacement glass windscreen is authorised under the following conditions;</p> <ul style="list-style-type: none"> <li>- The replacement screen must be of laminated glass construction.</li> <li>- The replacement screen must be certified for road use with an indelible marking as proof.</li> <li>- The replacement screen must weigh no less than the series screen.</li> <li>- The replacement screen may incorporate hot wire elements for demisting.</li> </ul> <p><b>FP</b></p> <p>The series (windscreen) wiper motor and mechanism may be modified (but not the sweep across the windscreen) to enable fitment of the safety cage. The rear wiper may be removed.</p>
<b>902</b>	<b>Front door windows:</b>
	<p><b>SP</b></p> <p>The series (door) windows may be retained, in which case their operating mechanisms must also remain operable. Alternatively, polycarbonate (door) windows are authorised under the following conditions;</p> <p><b>FP</b></p> <ul style="list-style-type: none"> <li>- The material must retain the original shape of the series part and shall have a minimum thickness of 3.8 mm.</li> <li>- Openings (with additional sliding windows) may be incorporated into the main window.</li> <li>- The whole window must be able to be removed (in an emergency situation) without the use of tools.</li> <li>- Energy absorbing (safety) foam must be incorporated within the interior part of the door (refer article 900 - Lateral side protection).</li> </ul>

902		<b>All other windows including rear windscreen:</b>
	<p><i>SP</i></p> <p><i>FP</i></p>	<p>The series windows may be retained, and the operating mechanisms are free.</p> <p>Alternatively, polycarbonate windows are authorised under the following conditions;</p> <ul style="list-style-type: none"> <li>- The material must retain the original shape of the series part and shall have a minimum thickness of 3.0mm</li> <li>- The rear screen shall have- a thickness of at least 3.0mm and shall be bonded to the window aperture using industry standard adhesive.</li> </ul>
		<b>Underbody protections / Mud-flaps:</b>
	<i>FP</i>	<p>The fitting of <b>underbody protections</b> is authorised under the following conditions;</p> <ul style="list-style-type: none"> <li>- They are made from an authorised material; Kevlar, Aluminium, steel or plastic.</li> <li>- They are designed to be removable.</li> <li>- They are designed exclusively and specifically to protect the following parts; Engine, Radiator, Suspension, Gearbox, Transmission, Fuel tank, Steering, Exhaust and Extinguishers.</li> </ul>
	<i>FP</i>	<p>Transverse <b>mud-flaps</b> shall be fitted to the bodywork that cover the whole width / height of each tyre [when viewed from the rear of the vehicle] and have a ground clearance between 50 mm and 100 mm [when the vehicle is stationary]. The material shall be flexible and have a minimum thickness of 4.0 mm.</p>
		END

# GROUP AP4

## PART THREE – APPROVED CONSTRUCTORS AND CONTROL PARTS LIST

### LIST 1 – APPROVED CONSTRUCTORS / COMPANIES

- I. The following companies are authorised to perform the bodyshell modifications as prescribed in PART TWO Article 9.0 of these regulations
- II. For the avoidance of any doubt, an ‘Approved Constructor’ is a company or individual who are authorised by the ASN being either MotorSport New Zealand or CAMS and are detailed below
- III. Expressions of interest to become an ‘Approved Constructor’ should be directed to the ASN of the country in which the applicant operates

Constructor / Company	Location	Physical Address	Contact information
Force Motorsport Limited	Auckland - New Zealand	Force Motorsport Ltd 399 Whitford Park Road, RD1 Whitford Auckland 2576 New Zealand	Andrew Hawkeswood – +64 (0)21 784 675
Race Torque Engineering	Perth - Australia	Race Torque Engineering Pty Ltd 16 Action Place Wangara Perth 6065 Australia	Lane Heenan - +61 8 930 26388
Team Ralliart NZ	Pukekohe – New Zealand	Team Ralliart NZ Unit 3/17 Sweetcorn Place Pukekohe 2120 New Zealand	Chris (Choice) Little - +64 (0)21 928 692 Bill Morton - +64 (0)9 238 5359
Emma Gilmour Promotions Ltd	Dunedin – New Zealand	TBA	Emma Gilmour - +64 (0)21 520 122
ProSpeed Motorsport	Tauranga	7/95 Birch Avenue, Judea Tauranga	David Loughlin - +64 7 578 0479 + 64 21 917866

# GROUP AP4 CONTROL PARTS LIST

## LIST 2 - CONTROL PARTS

Part Category;

- All Control Parts detailed hereunder shall be purchased from the nominated companies
- Control Design Parts are detailed hereunder for reference and may be freely sourced
- All other parts may be freely sourced

Part No. / Article ref.	Part description	Part category	Mandatory Supplier	Notes
900	Bodyshell / Safety Cage	CP	Refer List 1	The bodyshell fabrication and safety cage must be entrusted to a company as detailed in LIST 1 of these regulations. All of the control parts necessary during this fabrication will be supplied by the 'Approved Constructor'.
	Transmission tunnel	FP		The transmission tunnel will normally be part of the bodyshell fabrication although can be delegated
	Fuel tank box	FP		The fuel tank box will normally be part of the bodyshell fabrication although can be delegated
	Rear floor	FP		The rear boot floor will normally be part of the bodyshell fabrication although can be delegated
701	Front subframe (N/S engine installation)	CP	Force Motorsport Ltd	
701	Front subframe (E/W engine installation) Evo rack	CP	Force Motorsport Ltd	Supplied by Force Motorsport to match the control bodyshell mount points. Refer also front subframe mounting kit for the forward chassis side rail mount.
701	Front subframe mounting kit	CP	Force Motorsport Ltd	Mounting kit supplied to individually adapt the control part subframe to the front chassis side rail mounting point.
701	Rear subframe Sadev differential	CP	Force Motorsport Ltd	Supplied by Force Motorsport to match the control bodyshell mounting points.

701	Rear subframe X-Trac differential	CO	Ralliart Ltd	Supplied by Force Motorsport to match control bodyshell mounting points
701	Rear subframe mounting kit	CP	Force Motorsport Ltd	
	Seat mounts	FP		

## LIST 2 - CONTROL PARTS

Part Category;

- All Control Parts detailed hereunder shall be purchased from the nominated companies
- Control Design Parts are detailed hereunder for reference and may be freely sourced
- All other parts may be freely sourced

Part No. / Article ref.	Part description	Part category	Mandatory Supplier	Notes
701	Suspension control arms (front)	CP	Force Motorsport Ltd	
701	Suspension control arms (rear)	CP	Force Motorsport Ltd	
701	Suspension upright L/H	CP	Force Motorsport Ltd	
701	Suspension upright R/H	CP	Force Motorsport	
701	Suspension Upright Common	CP	Team Ralliart	Part No. AP4-044
701	Front brake mounting bell	CDP	Force Motorsport	
701	Rear brake mounting bell	CDP	Force Motorsport	



### LIST 3 – AUTHORISED GEARBOXES

Refer Part Two Article 603;

- The following list of gearboxes have received approval for use under these regulations
- Designated as 'Control Design Parts' the following gearboxes and component parts may be sourced from the manufacturer or through an appointed agent.

Article ref.	Manufacturer	Model Number	Model Type	Notes
603	Sadev	ST90-18	6 Speed sequential	
603	X-Trac	P1202	5-Speed sequential	
603				
603				
603				
603				
603				