

2023 Castrol Toyota Formula Regional Oceania Championship Technical Amendment

This amendment is issued under the provisions of the MotorSport NZ National Sporting Code Article 18(2) in confirmation that the following amendments, notices or points of clarification have been authorised to the text of the applicable Championship Technical Regulations. It is recommended that in addition to retaining a copy of this bulletin all parties modify the text of the regulations according to the following:

Championship Amendment

1. Amend Article 10.1.1 – Front Suspension as stated in the schedule below.

1. 10.1.1 Front Suspension

(...)

The caster of the front suspension must be set respecting the measurement defined by diagram below.

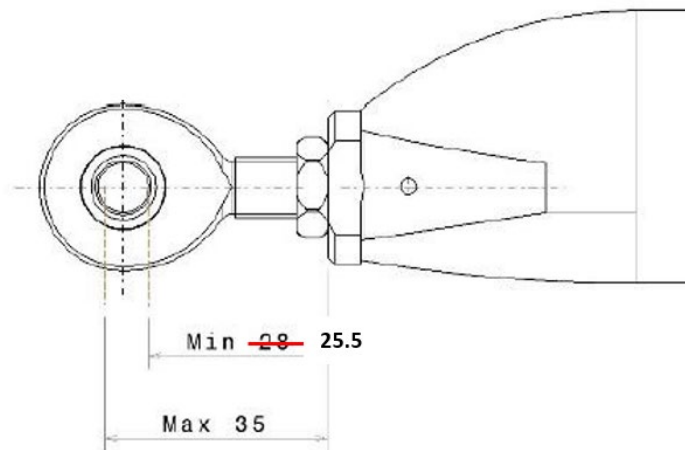

(...)

For clarification, Min & Max are defined from the centre of the spherical bearing.

Reason: To allow for the reduction of caster, and to clarify the caster measuring points.

This bulletin is issued by MotorSport NZ
Bulletin authorised by:

Devan Gregory
Technical Manager