

## 2021 Race Championship Series

### TOYOTA RACING SERIES Championship Technical Amendment (Schedule TRS)

*This amendment is issued under the provisions of the MotorSport NZ National Sporting Code Article 18(2) in confirmation that the following amendments, notices or points of clarification have been authorised to the text of the Supplementary Regulations of the above named event. It is recommended that in addition to retaining a copy of this bulletin all parties modify the text of the regulations according to the following:*

---

#### Championship Amendment

1. Amend Article 11.6 UMP Adjustment as stated in the schedule below.
2. Amend Article 11.7 Front Caster as stated in the schedule below.

---

1. **Item One:** Replace existing 11.6 with the following:

11.6 The only permitted UMP adjustment is the - 5 Position UMP configuration as defined by the diagram 11.6 below.

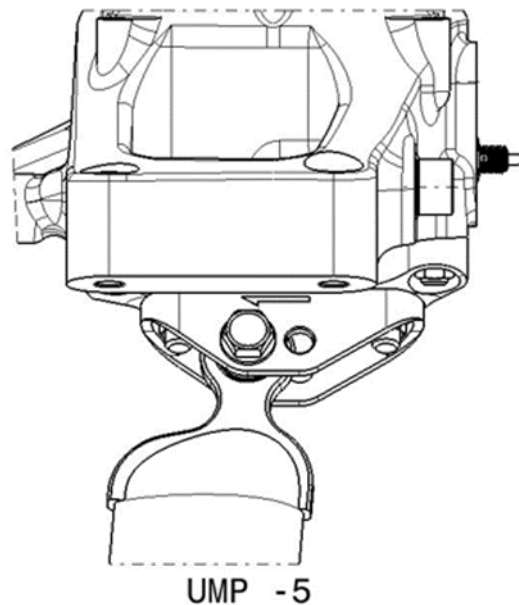

Diagram 11.6

Reason:

- 1 Confirmation of agreed 2021 suspension configuration.

2. **Item Two:** replace existing 11.7 with the following:

11.7 The caster of the front suspension must be set respecting the measurement defined by diagram 11.7 below.

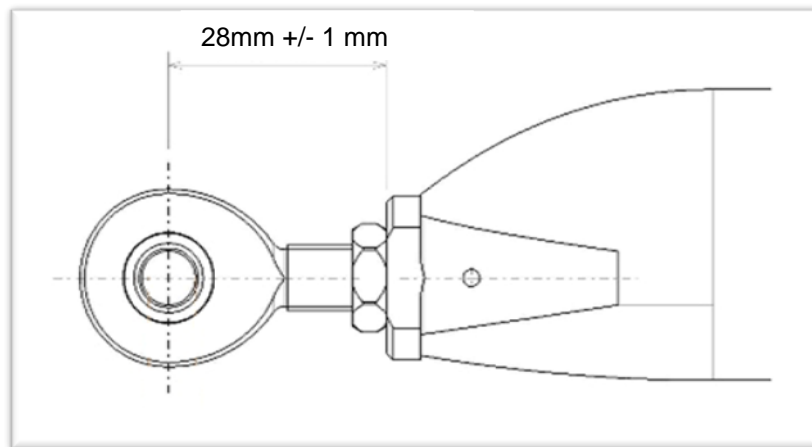

**Diagram 11.7**

**Reason:**

1. *Confirmation of 2021 suspension Caster configuration.*

---

This bulletin is issued by MotorSport NZ

Bulletin authorised by:

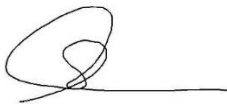

MotorSport New Zealand Inc.