

Manual Amendment - 36032

These amendments have been authorised to the text of MotorSport Manual Edition 36. It is recommended that in addition to retaining a copy of this amendment that all parties modify the actual text in their Manual according to the following:

Amendments to Schedule A – Part One in Manual 36:

1. Amend Article 8 – Use of Motorsport Vehicles on Public Roads as stated below.

1. Item One:

8. Use of Motorsport Vehicles on Public Roads:

(...)

8.3 LVV / MotorSport Authority Card

(...)

(6) Specific Requirements:

- (d) **Removal of a Manufacturer Occupant Protection System (MOPS):** from a vehicle (primarily used for motor sport competitions) may be authorised under the Authority Card system. The vehicle shall be fitted with and comply with the following:

(...)

- (ii) At a minimum, a full Safety Cage, in compliance with Schedule A, Part One, Article 4.6 and Part Two, Article 5.1 through 5.5 as per diagrams 8.3(6)(d) below. ~~incorporating forward reinforcements (terminating at a substantial structure such as the suspension strut tower) in full compliance with this Schedule; and~~

(...)

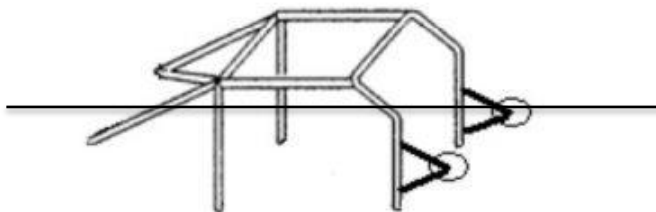

—Diagram 8.3(6)(d) — forward reinforcement —

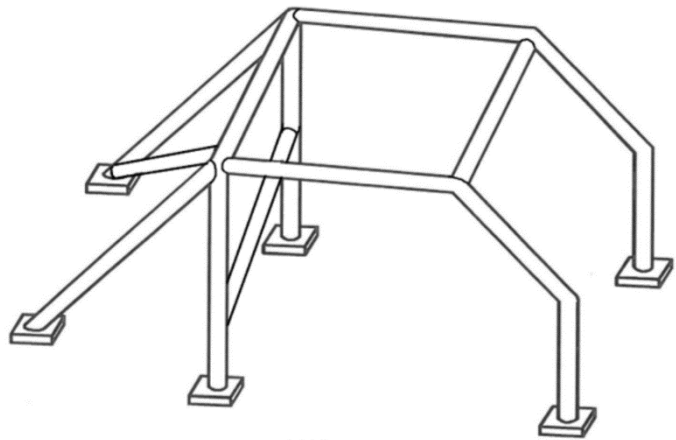

Diagram 8.3 (6) (d)

Reason: *To align motorsport requirements with updated LVVTA procedures for MOPS Removal.*

This amendment is issued for MotorSport New Zealand Inc by the Administration.

A handwritten signature in black ink, consisting of a large, stylized 'G' followed by a horizontal line.

Elton Goonan
Chief Executive Officer
MotorSport New Zealand