

ARTICLES GOVERNING THE 2023 New Zealand V8 Ute Racing Championship

Preamble

MotorSport New Zealand Inc hereby declares the following articles to be those governing competition for drivers in the MotorSport NZ, NZ V8 Ute Racing Championship.

These articles and appendixes are at all times to be read in conjunction with:

- The National Sporting Code (NSC) and its appropriate Appendices and Schedules,
- Schedule CH – Race Championship General Prescriptions
- The Technical Regulations – Schedule UR
- The Event Supplementary Regulations.

A Championship Permit No: 220544 has been issued in the name of MotorSport NZ.

OFFICIAL RECORD OF AMENDMENTS ISSUED TO THESE ARTICLES

This table records all official Amendments issued during the season relative to these Articles;

Amendment Number	Issue/Effective date	Article reference	Subject / Notes

1. INTERPRETATIONS:

In these Articles and associated Appendixes, the following expressions shall have the meanings set out:

The “**Championship**” means the MotorSport NZ, NZ V8 Ute Racing Championship for cars complying with Schedule UR; and

“**Inviting Clubs**” means the MotorSport NZ Clubs hosting Rounds of the Championship; and

“**NZV8UR Ltd**” means New Zealand V8 Ute Racing Ltd, the category owner; and

“**Round**” means the race meeting at which drivers may score points towards the Championship.

2. ELIGIBILITY:

2.1 DRIVER ELIGIBILITY

2.1.1 All drivers shall hold a C1 Grade Competition Licence or higher and if the Entrant is other than the driver, an Entrant’s Licence is required in the name of the Entrant.

***Note:** Under the provisions of the Trans-Tasman Visa Agreement between Motorsport Australia and MotorSport New Zealand Inc, Australian Competitors holding both Motorsport Australia General Competition Licences and Trans-Tasman Visas may enter any of the New Zealand Race Championships and be eligible for awards.*

2.1.2 All drivers and entrants must be financial members of an affiliated MotorSport NZ Club.

2.1.3 All drivers shall affix & wear:

- (1)** Embroidered nominated category sponsor patches on race suits (to be supplied by the category). The position of the patches will be as per the current NZV8UR Vis plan (refer www.v8utes.co.nz) and advised at the time of issue, and
- (2)** Caps will be supplied by the category and given out for podium presentations and are to be worn by 1st, 2nd & 3rd place getters for award presentations and photos.

2.2 VEHICLE ELIGIBILITY

2.2.1 Eligibility shall be for NZ V8 Ute Racing cars complying with the specification set out in Schedule UR.

2.2.2 All entrants and drivers shall agree to submit their vehicle to the eligibility and safety audits as and when required by the Championship **Technical Officer**. Any costs incurred during disassembly of components shall be met and accepted by the Competitor.

2.2.3 Category Seals may be applied by the Championship Coordinator and/or Championship **Technical Officer** and/or nominated assistant, to components and/or assemblies of components.

2.2.4 Permanent Race Numbers:

- (1) Competitors are reminded to contact the Championship Co-ordinators to reserve a race number for the season.
- (2) All Competitors must apply for a race number each season and cannot assume that the previous season's number is automatically retained.

2.2.5 Vehicle Decals: All vehicles shall reserve the spaces for the Championship and Sponsors' decals at all Rounds and carry competition numbers and Driver's name and Nickname in the locations and to the dimensions as set out in the NZV8UR Vis Plan Documents (Appendix One)

- (1) Competitors will be provided with Category and Sponsor decals which must be displayed in the prescribed positions in accordance with Appendix One.
- (2) Any competitor who fails to properly display legible decals or replace spoiled or damaged decals will be prevented from entering the track for hot laps, qualifying or racing and may be excluded from further participation in the Championship plus a penalty maybe issued.

3. OBJECTIVE:

- 3.1 To promote and foster NZ V8 Ute Racing by presenting Competitors with a well-promoted series creating worthwhile individual sponsorship opportunities with an enjoyable and relaxed competition in the spirit of NZ V8 Ute competition.

4. CHAMPIONSHIP PERSONNEL:

- 4.1 At each Round the following personnel, or their approved assistant, shall have the responsibilities and authorities set out:

- 4.1.1 **Championship Race Director:** Malcolm Glen
Mobile Phone No: 027 488 9966
E-mail:

Who is appointed and authorised by MotorSport NZ to be responsible for:

- (a) Ensuring compliance with MotorSport NZ National Sporting Code and its addendums, this Schedule, MotorSport NZ Race Championship Articles associated with the Championship series.
- (b) Undertaking duties and authorities outlined in NSC 78 & 79.
- (c) Conducting Race Director briefing sessions.
- (d) Liaising with the Approved Promoter regarding promotional activities.
- (e) Conducting any inquiries necessary (including any hearings and inquiries held outside of Rounds of the Championship) to resolve any issues and imposing any penalties arising therefrom that may arise during the conduct of the Championship series.
- (f) To be a Starting and Finishing Judge.
- (g) To be a Judge for yellow flag redressing.

4.1.2 Championship Coordinator: Cherie Brown
Mobile Phone No: +64 21 777 110
E-mail: cherie@v8utes.co.nz

Who is responsible for and authorised by MotorSport NZ to:

- (a) Deal with all administrative matters pertaining to the Championship, and
- (b) Record and publish all Championship points schedules, and
- (c) Liaise with the **Approved** Promoter and/or Inviting Club/s on all matters pertaining to these Articles, and
- (d) Ensure supply of competition number sets and correct placement of decals on competing vehicles.

Who may have deputies and assistants to whom they may delegate any of their responsibilities and authorities by way of **bulletin** during the Championship.

4.1.3 Championship Technical Officer: Keith Hargraves
Mobile Phone No: 021 253 2399

Who is responsible for and authorised by MotorSport NZ to:

- (a) Establish the NZ V8 Ute technical eligibility audit programme at each Round, and
- (b) Undertake safety audits including management of vehicle logbooks, tyre allocation and marking; and
- (c) Impound and affix seals as required, and
- (d) Undertake technical eligibility checking; and
- (e) Undertake the duties of a Technical Judge (NSC 86(d)) with respect to weights and measures; and
- (f) Undertake the duties of a Technical Judge (NSC 86(f)) with respect to tyres; and
- (g) Liaise with event Officials and Championship Coordinator on any scrutineering or technical conformity issue for the category; and
- (h) Report to the senior MSNZ Technical Officer on duty or Race Director as appropriate at rounds with their proposed technical checking programs and subsequent results prior to the final Stewards' meeting.

Who may have deputies and assistants to whom they may delegate any of their responsibilities and authorities by way of **bulletin** during the Championship.

4.2 All correspondence shall be addressed to the Championship Coordinator who is authorised to carry out all the necessary administrative duties for the Championship.

5. CHAMPIONSHIP ENTRY:

- 5.1 Entry into the Championship Rounds will be made through the Round Organiser's online entry link which will be circulated via email by the Championship Co-Ordinator.
- 5.2 In submitting an entry into any of the Championship Rounds, all Entrants and Drivers:
- (1) Are deemed to be in acceptance of these Championship Articles as they are presented,
 - (2) Agree to comply with these Articles, and those of the National Sporting Code, and
 - (3) Shall be at all times responsible for the presentation of their competing vehicle with respect to safety requirements under Schedule A, and eligibility requirements under the Technical Regulations, Schedule UR, and
 - (4) Are deemed to be in acceptance of, and will at all times comply with NZV8UR Ltd acceptable standard of overall vehicle and pit area presentation with respect to panel, paint, decals, signwriting & general appearance or any other specific requirements or requests of the official Championship Sponsors, as detailed by NZV8UR Ltd, and
- (3) Shall be at all times responsible for the conduct of their self and any person associated with that driver and their entry ensuring that their conduct will not, in anyway, be deemed to bring the Category into disrepute.

6. CHAMPIONSHIP STRUCTURE:

- 6.1 The Championship will comprise the following Rounds:

Round	Date	Venue	Hosting Club
1	10-12 February 2023	Taupo	MotorSport NZ
2	24-26 March 2023	Pukekohe	Speedworks Motorsport Club
3	14-16 April 2023	Manfeild	MotorSport NZ
4	5-7 May 2023	Hampton Downs	MotorSport NZ

- 6.1.1 MotorSport NZ reserves the right to either cancel or amend any Rounds of the Championship without affecting in any way its powers to award any title.

7. CHAMPIONSHIP FORMAT:

- 7.1 **Testing:** Testing of a NZ V8 Ute Racing Championship vehicle on the circuit at which the Round is scheduled to be held prior to the event is not permitted within the seven(7) days prior to the Round commencing as stated per the published events schedule.

However, a Novice Competitor may be permitted to test for one(1) day within that seven-day period upon application to the Championship Coordinator with approval from the Race Director.

- 7.2 **Practice:** There will be a minimum of one(1) practice session of fifteen(15) minutes in duration. No other on-track testing opportunities will be available once the Meeting commences on Friday unless permission is obtained from the Race Director.
- 7.3 **Qualifying:** There will be one(1) qualifying session of a minimum of twenty(20) minutes duration.

- (1) For the duration of Qualifying all vehicles not on the circuit are to remain on the Pit Lane Apron and shall not enter the Pit garages. No refuelling is permitted during the Qualifying session.

7.4 Race Distances: There are planned to be three(3) Races at each Round, run to the following format:

Round	Race 1	Race 2	Race 3
1	8 Laps	12 Laps	10 Laps
2	8 Laps	12 Laps	10 Laps
3	8 Laps	12 Laps	10 Laps
4	8 Laps	12 Laps	10 Laps

7.4.1 At all Rounds the Race Director, and the Championship Coordinator, in consultation with the Stewards, reserves the right to shorten and/or cancel races in the case of Force Majeure.

7.5 Race Starting Positions: all Races shall be a standing start in accordance with the provisions of Schedule Z. Starting positions shall be determined as follows:

- (1) Starting Positions for **Race One** will be determined by Qualifying Times, fastest driver to the front.
- (2) Starting Positions for **Race Two** will be determined by the finishing positions of Race One with the first ten(10) cars in reverse grid formation. The remaining cars will start in order of finishing from Race One. Where more than one(1) driver fails to finish Race One, their starting order will be from the rear of the grid in order of their qualifying times (the fastest qualifier to the front).
- (3) Starting Positions for **Race Three** will be determined by the points achieved in Races One and Two with highest points scorer to the front. Should more than one(1) driver be on the same number of points, such drivers will be placed in order of qualifying times.

7.6 Novice Competitors may choose to start from the rear of the grid in any race of the Championship.

7.7 Any competitor who fails to record a lap time in Qualifying shall start from the rear of the grid for Race One.

7.8 Any competitor who fails to take the finish flag for Race One shall start from the rear of the grid for Race Two.

7.9 All Grid positions will be subject to any penalties issued during qualifying or race(s) during the current round and shall result in a relocation of a drivers starting position for the driver's next Race.

8. PARC FERMÉ:

8.1 When directed by Race Radio or the Championship Technical Officer or their assistants, Competitors are required to drive their competing vehicle directly (and without any team personnel or crew intervention) from the track to the designated Parc Fermé, the location of which will be notified by the Championship Technical Officer.

Notes:

1. *Parc Fermé for NZV8UR Utes will be your allocated pit tent unless advised of an alternate designated Parc Fermé area by the Championship Technical Officer.*
2. *Drivers should ensure that they and all their team personnel are familiar with the Parc Fermé regulations and limitations in the National Sporting Code Article 60.*

8.2 The Championship Technical Officer may authorise the entry of team personnel for the purposes of vehicle eligibility inspections.

8.3 Unless the Championship Technical Officer consents in each particular case, any car unable to proceed to Parc Fermé under its own power must nevertheless be delivered there as soon as practicable.

9. RACE RADIO

9.1 Race Radio is compulsory and will be used for all major announcements, including race penalties and to communicate with team managers and drivers concerning incidents and racetrack penalties.

9.2 The frequency is **455.168750MHz**.

9.2.1 Any race radio tuned to the above frequency must be set to “receive” only.

10. PENALTIES, PROTESTS and APPEALS:

10.1 Penalties shall be applied in accordance with the prescribed articles of NSC Part VIII – Penalties, Schedule P, and Schedule CH.

10.2 **Series Demerit Points:** may be applied in accordance with Schedule CH.

10.3 **Reverse grids:** If a Competitor receives any penalty during a Meeting that will give a positive effect for a reverse grid start then they will be placed at the rear of the reversed section of the grid.

11. TYRE TYPE, ALLOCATION AND MARKING PROCEDURES:

11.1 Only the Control Tyres as detailed in Schedule UR which are purchased direct from the control supplier NZV8UR are permitted for any Round of the Championship.

11.2 Only the control tyre may be used for practice(s), qualifying, races and meeting ride sessions.

11.3 A maximum of six(6) new Control Dry Tyres will be marked for each vehicle by the Championship Technical Officer or their nominated assistant at the first meeting of the season and only four(4) new tyres each meeting thereafter. These are the only tyres permitted to be used on that vehicle during any qualifying session or race.

11.3.1 The number of Control Wet Tyres are free and are not subject to tyre marking.

- 11.4** Of the six (6) tyres initially and four(4) thereafter referred to in 11.3 above, a minimum of two(2) of these tyres must be new and must be fitted to the front of the vehicle during qualifying. Two(2) other tyres may be new or used and must be fitted to the rear of the vehicle during qualifying. The remaining two(2) tyres thereafter are to be previously marked for use in the 2023 season and **must** show clear evidence of being previously used. This will be determined by the Championship Technical Officer.
- 11.4.1 Ford BF only:** of the six (6) tyres referred to in 11.3, only two(2) of these tyres are permitted to be new and presented for marking per round as detailed in 11.3. The remaining four(4) tyres are to be previously marked for use in the 2023 season and **must** show clear evidence of being previously used. This will be determined by the Championship Technical Officer.
- 11.5 For Round 1 only:** Six(6) new Control Tyres may be purchased for marking, however four(4) new Control Tyres must be fitted to the vehicle for qualifying and the remaining two(2) new Control Tyres must be used during any race at that Round.
- 11.5.1 Ford BF only: For Round 1 only:** Four(4) new Control Tyres may be purchased for marking, however two(2) new Control Tyres must be fitted to the vehicle for qualifying.
- 11.6** Where a driver enters the Championship after Round 1, tyre allocation will be in accordance with Articles 11.1-4.
- 11.7** Except for the provisions of Articles 11.5 and 11.10, it is not permitted to start any race on new tyres that have not been previously run as per Articles 11.3 and 11.4.
- 11.8** Following the completion of the qualifying session, any of the six(6) tyres detailed in Articles 11.4 and 11.5 above may be used without restriction as to its location on the vehicle.
- 11.9** Any tyre that has worn below any of the tread depth indicators in the middle section of the tyre or shows signs damage which is deemed unsafe will not be permitted to be used for testing, practice(s), qualifying, races and meeting ride sessions.
- 11.10** Competitors are permitted to replace two(2) marked tyres in accordance with Articles 11.3 and 11.4 above per vehicle if the Championship Technical Officer is satisfied that due to exceptional circumstances, the tyre in question can no longer be used. The Championship Technical Officer shall ensure that the replacement tyre is a previously marked and used tyre, if no previously used tyre is available a new tyre maybe permitted. They are to withdraw the marking for that meeting of any tyre replaced and mark the replacement tyre as one of approved allocation.
- 11.11 Specifically prohibited for all tyres are the following modifications:**
- Hand cut tread grooves,
 - Filing and buffing,
 - Tyre warmers,
 - Chemical treatments, and
 - Any means of artificially enhancing tyre performance.
- 11.12 Tyre marking;** will take place at a time stipulated by the Championship Coordinator or Championship Technical Officer prior to the Round, but the time will be prior to qualifying. Each Competitor must present all six(6) tyres mounted on their wheels for marking at the front of their respective garage / marquee bay. If raining all six(6) wheels / tyres must be placed in the marquee bay beside the competition vehicle. All wheels / tyres must be removed from the vehicle for marking as all tyres will be marked on the inside & outside edges.

- 11.13** If qualifying and / or racing are scheduled on more than one(1) day at a meeting, the Championship **Technical Officer** may impound any tyres overnight.
- 11.14** It is the Competitor's / Crew's responsibility to ensure that all tyre markings remain clearly visible throughout the Round. Whenever a tyre marking becomes illegible, the Competitor or Crew must advise the Championship **Technical Officer** accordingly, who will decide upon the appropriate course of action.
- 11.15** **Wet tyres:** wet tyres must be used when a qualifying session or a race is declared wet. If a qualifying session or a race is declared wet, all four wheels must be fitted and running with wet tyres.
- 11.15.1** Where a qualifying session has been declared wet, the dry control tyre allocation as detailed in 11.3 and 11.4 may be used indiscriminately throughout that round.
- 11.16** At all meetings, the control dry tyre must be used unless the meeting is declared wet by the Clerk of the Course in conjunction with the Race Director.
- 11.17** When a meeting is declared wet by the Clerk of the Course in conjunction with the Race Director, the use of DRY specification tyres is prohibited, and rear rain lights must be illuminated. These conditions will remain in place until the WET status is lifted.

12. COMPETITOR DATA ACQUISITION SYSTEMS

- 12.1** All systems of data recording, including cameras, fitted to the car by the Competitor or Entrant shall be made available, upon request by the Race Director, Clerk of the Course or MotorSport NZ in a format acceptable to the officials. Competitors are required to save a copy of all the data from the Event without modifying or deleting the data until fourteen(14) days after the finish of the Event.

13. IN CAR CAMERA (Judicial Camera):

- 13.1** **Camera Installation:** All camera installations must be approved by the Championship Coordinator and/or Championship **Technical Officer**.
- 13.1.2** It is compulsory for each vehicle to be fitted with judicial in-car camera(s) in accordance with Schedule CH. The camera kit, data card and mounting bracket will be supplied by the Championship Coordinator or their appointed official and it is the competitor's responsibility to ensure it is fully operational during all meeting sessions.
- 13.1.3** The camera(s) must be hard wired direct to an engine running power-only source, i.e. engine fuel pump, **not** the ignition key on accessory position or direct battery source or any accessory power nor any manual on / off switching mechanism.
- 13.2** **Camera Operation Procedures:**
- 13.2.1** In Car Camera operation is the responsibility of each individual team. Camera must be checked prior to the Ute leaving pit bay and ENSURE card inserted, unit is turned on and recording. Recording starts when ignition on. Failure to do so will result in penalty.
- 13.2.2** The in-car Cameras are the sole property of the Category and are to be used only for category in car footage and judicial purposes. DO NOT insert these cards into personal laptops.

13.2.3 Cards may be collected post-race by Category Officials.

13.3 Footage rights and obligations: Where in-car judicial camera(s) are fitted, video cards cannot be removed nor can any footage be downloaded by a driver or crew or any other person other than a category or Championship official during any Round until each Round is completed, any judicial enquiries have been completed and final results published.

13.3.1 For any Ute that has its judicial camera equipment, camera card or footage tampered with or camera card or footage is missing during a Round or the camera card missing at the beginning of each Round, the driver will incur a penalty and will additionally be invoiced a fee for the replacement of the removed card.

13.4 At the conclusion of the Meeting, no competitor may leave the venue until the in-car judicial camera data card has been removed from the competition vehicle by either the Championship Coordinator or their delegate.

13.5 In addition to category judicial cameras, it is permitted for a competitor to fit their own in-car cameras. All video footage must be made freely available to the Category and event officials if and when requested.

14. POINTS:

14.1 Points will be allocated to all eligible Drivers based on their overall finishing positions at each race at each Round of the Championship as detailed in Article 14.2 below.

14.2 Points will be allocated to drivers of each race of the Championship on the following basis:

Placing	Points	Placing	Points	Placing	Points
1 st	35	9 th	17	17 th	9
2 nd	31	10 th	16	18 th	8
3 rd	27	11 th	15	19 th	7
4 th	24	12 th	14	20 th	6
5 th	22	13 th	13	21 st	5
6 th	20	14 th	12	22 nd	4
7 th	19	15 th	11	23 rd	3
8 th	18	16 th	10	24 th	2
				25 th	1

14.3 Points shall only be awarded to the Drivers classified as finishers in the final results of each race.

14.4 Any race which is stopped and not restarted, and during which less than 50% of the race distance has been completed by the leader, shall be deemed a non-race in respect of Championship points and no points shall be awarded.

14.5 Any race which is stopped and not restarted, during which 50% – 75% of the race distance has been completed by the leader, shall be deemed to have been completed in respect of Championship points but only 50% Championship points shall be awarded.

14.6 Any race which is stopped during which 75% or more of the race distance has been completed by the leader, shall be deemed to have finished and a full allotment of Championship points shall be awarded.

- 14.7** The results for each Round shall be determined by the total number of points scored by each Driver at that Round.
- 14.8** In the event of a tie at the end of any Round, the final positions for that round shall be determined by comparing the results of each of the tied Drivers in the final race of that round. The higher place in the round results shall be awarded to the Driver with the higher finishing position in the final race.
- 14.9** The Driver gaining the highest points total over the **four(4)** Rounds of the Championship shall be declared the winner of the Championship.
- 14.10** In the event of a tie at the end of the Championship, the final positions shall be determined by comparing the race results achieved by each tied Driver, with the Driver with the highest number of first places being awarded the higher Championship position. If at this stage a tie still exists, it shall be resolved by comparing the number of second, third or fourth places (and so on) achieved by each tied Driver until each position has been determined.
- 15. PRESENTATION & AWARDS:**
- 15.1** At the Annual MotorSport NZ Awards function the Overall Championship winner as determined by overall Championship points awarded from all Rounds of the Championship will be awarded the NZ V8 Ute Racing Series Cup.
- 15.2** The presentation of any other Championship Awards shall be made at the conclusion of the Championship, at a time and place and in a manner as specified by NZV8UR Ltd.
- 15.3** The podium presentation arrangements will be contained in documentation relating to that Meeting. Details and operating requirements will be clarified to category co-ordinators prior to each round, by email, from MotorSport NZ or by the MotorSport NZ Approved Promotor.



APPENDIX ONE

RYCO 24.7 V8 Ute Championship Commercial Partners

Vis Plan List & Positions - 2023 Season

Effective: 30 July 2021

POSITION NO.	DECAL DETAIL	LOCATION ON UTE <i>Refer Vis Plan for location on Ute</i>	SIZE	SUPPLIED BY
Position 1	RYCO 24.7	Front Windscreen Top Banner		Category
Position 38	RYCO 24.7 V8 Ute Logo	Centre Roof - Diamond Decal	600mm x 600mm (tip to tip)	Category
Position 7	Currently trying to fill	Front of Roof Decal (roof banner)	185mm High	Category
Position 35	Currently trying to fill	Front Windscreen Lower Banner	120mm High	Category
Positions 41	RYCO 24.7	Head Lights		Category
Positions 6 & 42	Not in Use OR Available	Front Bumper Below Headlights	Decal 245 x 88mm	N/A
Positions 21	PTS Logistics	Front & Rear Number Plates Fords – Corflute Front & Rear Holden – Corflute Front & Decal Rear	Corflute 360 x 120 x 3.5mm Vinyl 360 x 120mm	Category
???	Available for own use until required again by Category	External Wing Mirror		N/A
Position 13	Race Brakes	Side Sills	Decal 245 x 88mm	Category
Position 14	Yokohama	Side Sills	Decal 245 x 88mm	Category
Position 15	I Print On Demand	Side Sills	Decal 245 x 88mm	Category

POSITION NO. <i>Refer Vis Plan for location on Ute</i>	DECAL DETAIL	LOCATION ON UTE	SIZE	SUPPLIED BY
Position 16	Yokohama	Side Sills	Decal 245 x 88mm	Category
Position 17	PTS Logistics	Side Sills	Decal 245 x 88mm	Category
Position 18	Not Sold	Side Sills	Decal 245 x 88mm	Category
Position 19	Not Sold	Side Sills	Decal 245 x 88mm	Category
Position 20	Not Sold	Side Sills	Decal 245 x 88mm	Category
	Motorsport NZ	Championship Decal	Left of Rear Screen	MSNZ

Drivers Signwriting Kit:

Driver Names, Nic Names & Race Numbers & Pit Tent Header Board will all be supplied by Category, for NEW DRIVERS.

If there is a change of driver or back to the original driver then the cost to redo the Drivers Signwriting Kit will be at your cost.

NZV8UR will order your Drivers Signwriting Kit from the category contract sign writer to keep consistency.

POSITION NO.	DECAL DETAIL	PLACEMENT	SIZE – FONT TYPE – COLOUR DETAIL	SUPPLIED BY
Position 34	Drivers Surname	Both 1/4 windows (Vertically in Capitals)	Font: Helvetica Bold – White Size: to fit window	Category
Position 37:	Drivers Surname (was nickname)	Lower LHS Front Screen Fix 25mm above bottom of windscreen and 25mm in from LH edge of screen	60mm high Helvetica Bold – Dayglo Yellow	Category
Position 36:	Drivers Full Name	Centre Rear Screen & above rear deck lid Fix centrally on rear screen	60mm high Helvetica Bold – White	Category
Position 32:	Race Numbers	Front & Rear Screens	130mm high Dayglo Yellow in Snyder Speed	Category

POSITION NO.	DECAL DETAIL	PLACEMENT	SIZE – FONT TYPE – COLOUR DETAIL	SUPPLIED BY
	Race Numbers	Door Windows - placement top rear corner of each window <i>Note: Numbers must remain visible at all times while on race track, ie. Door windows cannot be down</i>	150mm high Dayglo Yellow in Snyder Speed	Category
Driver Pit Bay Sign	Race #, Name & Category Logo	Pit Bay (cable tied to marquee)		Category

Drivers Overall Patches

BADGE	PLACEMENT	SUPPLIED BY
RYCO 24.7 V8 UTES	LH Breast placement on drivers overalls	Category
RYCO 24.7	RH Breast placement on drivers overalls	Category



V8UTE RACING NEW ZEALAND - FORD VEHICLE ID GUIDE

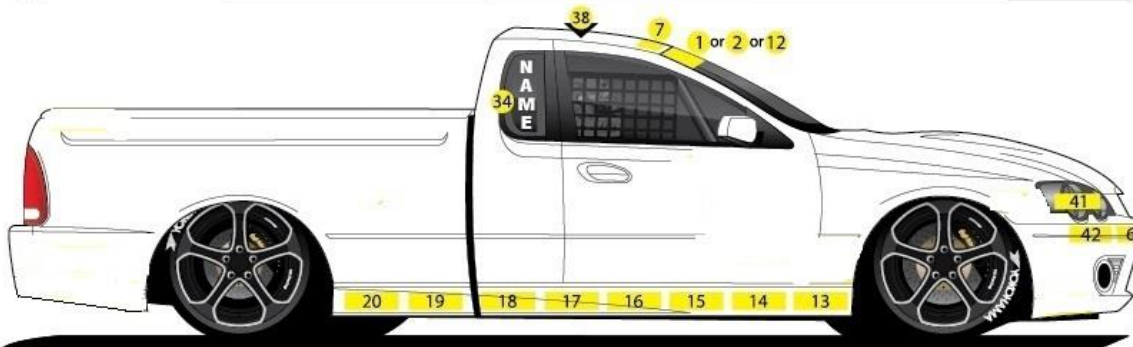
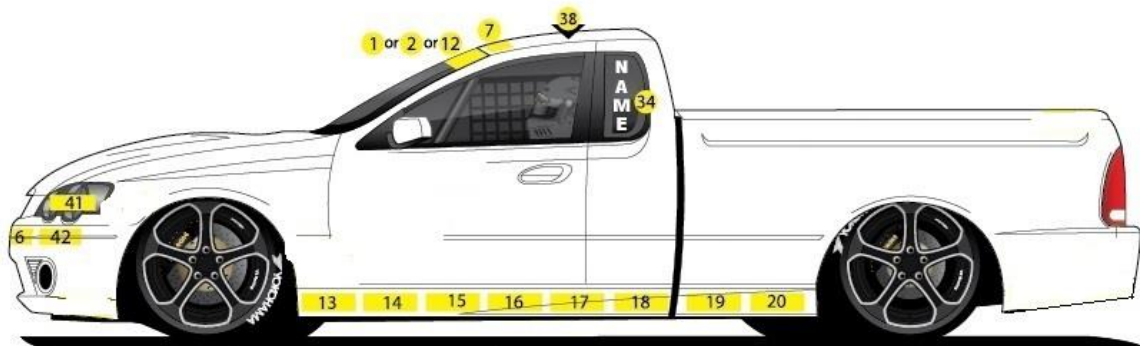

V8UTE RACING NEW ZEALAND - FORD VEHICLE ID GUIDE

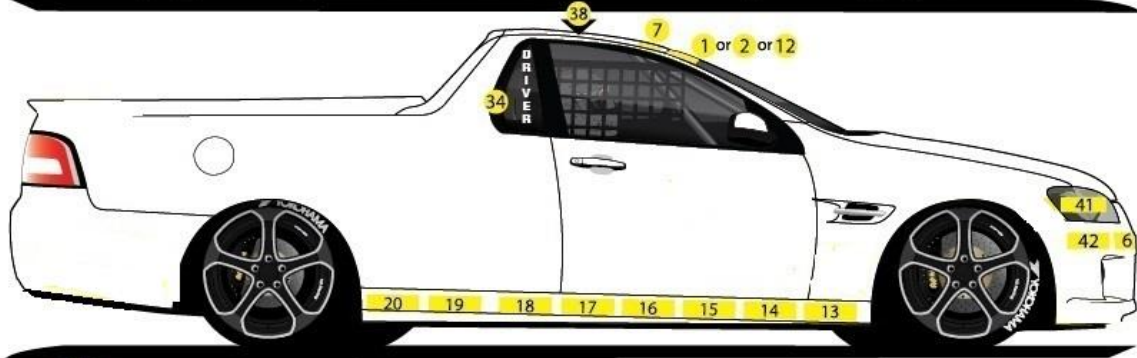
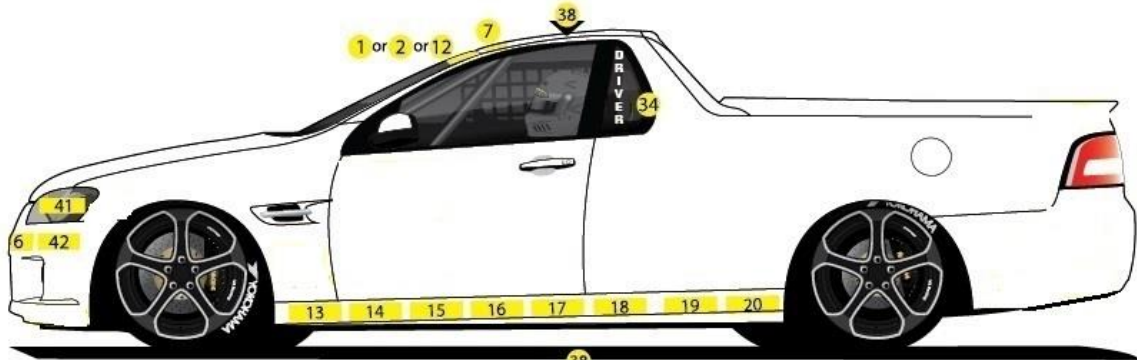

V8UTE RACING NEW ZEALAND - HOLDEN VEHICLE ID GUIDE

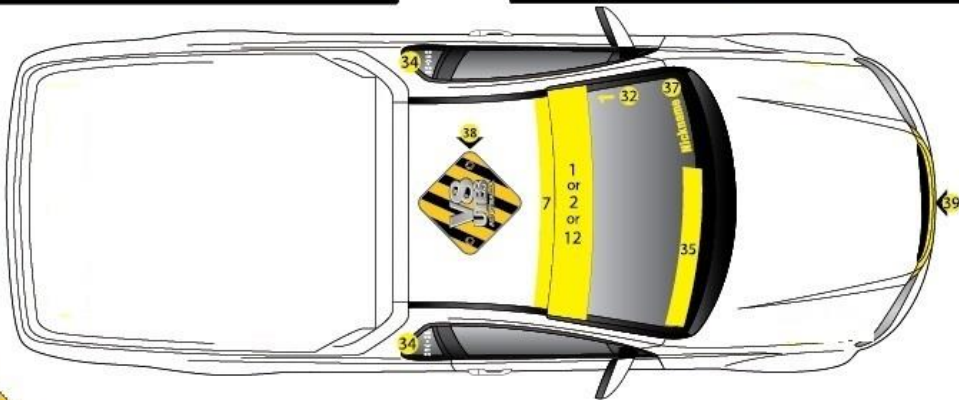

V8UTE RACING NEW ZEALAND - HOLDEN VEHICLE ID GUIDE