

SCHEDULE S6[©]

NZ SIX Race Series TECHNICAL REGULATIONS 2023–2024 Super Six Saloons

PREAMBLE

The overlaying philosophy of Super Six Saloons is;

- To provide an affordable entry to a professionally organised National Motor Race Series that emphasises driver ability rather than purchased technical advantage.
- To provide a tool through which anyone wishing to enter, continue or re-enter motorsport, can do so at a realistic cost.
- To regulate through MotorSport New Zealand the said Series stringently to provide fair competition for all.
- To always keep regulations simple, straightforward and along the lines of “it shall remain standard unless specifically stated otherwise”.
- To never allow freedoms within the regulations that would allow the Class to become “dollar orientated”.
- To constantly monitor the progress and growth of the Series to ensure that the Series continues to meet its objectives with the intent of maintaining an appropriate vehicle age to be attractive to competitors, sponsors and spectators.

COMPETITOR RECORD OF AMENDMENTS ISSUED TO THIS SCHEDULE

Use this table to keep a record of all official ‘Manual / Series Amendments’ issued during the season relative to this Schedule;

Amendment Number	Issue/Effective date	Regulation reference	Subject / Notes

MotorSport New Zealand reserves the right to amend these regulations at any time.

1. GENERAL INFORMATION RELATIVE TO THIS SCHEDULE

- 1.1 This Schedule shall be read in its entirety and shall take precedence over Appendix 2 Schedule A of the National Sporting Code contained in the current edition of the MSNZ Manual except where an item is not specifically covered within these regulations, in which case Appendix 2 Schedule A will apply.
- 1.2 All text changes from the previous issue of this Schedule are highlighted such. Text changes for grammatical and/or formatting reasons are not highlighted.
- 1.3 Efforts to find, bend or take advantage of perceived loopholes in these regulations or specifications will not be tolerated.
- 1.4 All cars competing in Events to which these regulations apply shall have a valid MotorSport NZ logbook.
- 1.5 **TECHNICAL ELIGIBILITY AND SAFETY EQUIPMENT ENQUIRY:** Where any doubt may exist in understanding any regulation contained within this Schedule it will be understood that it is the Competitor's obligation to enquire as to the correct interpretation. All technical eligibility and/or safety equipment enquiry shall be submitted in writing to:
- (a) The Series Scrutineer, as detailed in the Series Articles, then to
 - (b) The MotorSport NZ Technical Manager, where:
 - (i) All enquiries should detail the article in question and the specific subject matter.
 - (ii) A written reply will always be given to a written enquiry.
 - (iii) On matters of technical eligibility and/or safety compliance, a verbal statement will have no validity.
- 1.6 These regulations are based on Holden Commodore V6 3.8 litre sedans and Ford Falcon six cylinder 3.9 and 4.0 litre sedans, manufactured in Australia and marketed in Australia and New Zealand by General Motors Holden and the Ford Motor Company, and restricted in specification to those listed herein. These regulations are also restricted in specification to those listed in factory workshop and parts manuals relevant to each model.
- 1.7 The vehicles are to be representative of mass-produced family sedans with limited modifications permitted, all of which are designed to make the cars more suitable for competition use, thereby producing an affordable race series where the vehicles have even performance and driver ability is emphasised over vehicle tuning and preparation.
- 1.8 No components may be altered, modified, or changed, nor be other than original equipment parts unless specifically authorised in the regulations. The re-siting of components is considered to be a modification.
- 1.9 Any aspect relating to the construction and/or modification of the vehicle which is not expressly permitted in these regulations is forbidden. Modifications permitted are allowed only on the condition that weights, specifications and/or dimensions mentioned within these regulations are adhered to.
- 1.10 All vehicle parts and specifications are to remain consistent with the nominated model as supplied by the vehicle manufacturer at any given date. This prohibits the mixing of components from different production dates/series into a single vehicle, unless specifically authorised within these regulations. Any modification or alteration shall be undertaken with the application of recognised automotive engineering standards.
- 1.11 The vehicle models and the performance parity between the vehicle models will be amended as necessary. To achieve performance parity vehicle weight adjustments may apply.

2. DEFINITIONS

2.1 Definition of terms used within these regulations:

'**The Club**', '**NZ Six**' or '**Super Six Saloons**' means Saloon Car Racing New Zealand Incorporated (SCRANZ).

'**Competing weight**' means the minimum weight of the competing car in Race Trim. It may be measured at any time during the qualifying sessions and/or races, on the official scales of the meeting.

'**Controlled Component**' means a component that is fully controlled in respect of its specification, application and supply, and where specified shall be fitted.

'**Cup Class**' applies to Ford Falcon EA & EB (Series 1 EB only) and Holden Commodore VN & VP (non-IRS).

'**MSNZ**' means MotorSport New Zealand.

'**MSNZ Manual**' means the current edition of The Official MotorSport New Zealand Manual as published on the MSNZ website.

'**Non-standard**' means those components which are not "standard".

'**Race Trim**' means the condition in which the car competes, and shall include all fluids, ballasts and the driver.

'**The Series**' means any NZ SIX Race Series bound by these technical regulations.

'**Standard**' or '**OEM**' means the component/s as originally optioned or fitted to the make, model and type of car by the manufacturer at the time of the initial sale.

'**Trophy Class**' applies to Ford Falcon AU and Holden Commodore VT, VX, VY & VZ.

3. ELIGIBLE VEHICLES

3.1 Cup Class

3.1.1 Holden Commodore VN & VP

(a) Vehicles eligible are the four-door Holden Commodore VN & VP sedans (non-IRS / live axle) with 3.8 litre V6 engines, five-speed (T5) manual transmissions, and four-wheel disc brakes. The eligible vehicles are described by the manufacturer VIN prefix 6H8VNK19, 6H8VNL19, 6H8VNX19, 6H8VPK19 and 6H8VPL19.

3.1.2 Ford Falcon EA & EB

(a) Vehicles eligible are the four-door Ford Falcon EA & EB (Series 1 EB only) sedans with 3.9 litre six cylinder MPI engines, five-speed (T50D) manual transmissions and four-wheel disc brakes. The eligible vehicles are 18733, 18933, 18133, 18734, 18934, 18134, 18737, 18937 and 18132.

3.2 Trophy Class

3.2.1 Holden Commodore VT, VX, VY & VZ

(a) Vehicles eligible are the four-door Holden Commodore VT sedans with 3.8 litre V6 engines and five speed manual transmissions.

(b) It is permitted to use a four-door Holden Commodore VT, VX, VY or VZ sedan bodyshell in which case each requirement and regulation for the Holden Commodore VT must be applied, except where specified in these regulations.

3.2.2 Ford Falcon AU

(a) Vehicles eligible are the four-door AU Ford Falcon sedans with 4.0 litre six-cylinder MPI engines, five-speed manual transmissions, live rear axle assemblies and four-wheel disc brakes.

3.3 Scrutineers shall refer to the workshop manuals and the parts catalogues published by General Motors Holden and the Ford Motor Company of Australia specific to the respective vehicle. Scrutineers may also carry out direct scrutineering by comparison with a genuine Holden or Ford part obtained from a recognised dealer.

3.4 Vehicles that have previously competed in an Australian Saloon Car racing series will be eligible for Super Six Saloons, provided the unmodified safety cage is homologated by MSNZ, the vehicle conforms in every respect to these technical regulations OR the current Saloon Cars Australia Technical Regulations published by MotorSport Australia (Group 3K - Saloon Cars), save for any *controlled component* specifically required for the Series, and the prescribed inspection fee has been paid to the Club. The original vehicle logbook shall be made available to Series Officials upon request. Any subsequent modification or repair shall be required to comply with these technical regulations.

4. PARTS (INCLUDING CONTROLLED COMPONENTS)

4.1 Parts specified in the table below may be from any source unless specifically required otherwise in these regulations provided that their use does not result in the unauthorised modification of any other component:

fasteners, nuts, bolts & screws	gaskets
shims & spacers	piston rings
lamps	cylinder head valves
battery, clamps & leads	valve guides & pushrods
spark plugs & leads	torsional damper (harmonic balancer)
auxilliary gauges	engine belts
auxiliary bonnet & boot-lid fasteners	starter motor
seals	alternator
bearings	distributor
water pump	clutch pressure plate
water hoses & clamps	clutch driven plate
thermostat	clutch throw out bearing
fan	gearbox components
brake caliper repair kits	differential components
brake master cylinder	idler pulleys
universal joints	gear shifter
CV joints	tie rods
filters	fuel pumps
brake rotors	suspension stabiliser bar link pin kits
coils	suspension bushes
coil packs	internal rear view mirror
wheel bearings	

- 4.2 Non-genuine or non-OEM replacement parts specified in the table below is permitted. The parts shall remain standard replacement parts in terms of configuration and functional dimensions and be of similar material, and shall not result in any unauthorised modifications to any other component. The part being purchased as a standard replacement part shall be readily available from most New Zealand stockists (proof of purchase and part numbers may be required), and it shall not be machined or altered for the purpose of fitment or operation, other than as prescribed in these regulations.

tie rod ends	rear axles
ball joints	valve rocker covers
Falcon AU trailing arms	window glass
rear brake caliper mountings	head light, indicator & tail light assemblies

- 4.3 “Controlled Component” parts specified in these regulations shall be purchased through the Club unless specifically authorised otherwise.

	North Island	South Island
	Brent Cooper	Russell Keeler
Mobile:	027 313 3009	027 436 8685
email:	brent@wairarapamitsubishi.co.nz	rdkeeler@xtra.co.nz

- 4.4 It is forbidden to modify, alter, change, reclaim or paint any “Controlled Components” unless specifically authorised within these regulations.
- 4.5 Where “Controlled Component” is specified within these regulations only those components specified for a particular vehicle may be fitted to the vehicle.
- 4.6 Proof of purchase of “Controlled Components”, by way of an invoice or other authenticated document may be required.
- 4.7 Wherever an ACL component is specified, a Mahle or Nason branded component with the same part number may be utilised as an alternative.

5. SEALING OF COMPONENTS

- 5.1 Each engine, transmission, final drive assembly and the Electronic Control Unit (ECU) shall be sealed prior to the commencement of any qualifying session or race.
- 5.2 Competitors shall have the following locations predrilled with at least 2mm holes to enable wire type seals to be easily fitted:
- Cylinder head/s to block
 - Front pedestal bolts (Falcon EA & EB and Falcon AU)
 - Sump to block (leaving timing cover free to be removed)
 - Intake manifold to cylinder head/s
 - Throttle body to inlet manifold
 - Bell housing to block
 - Gearbox tail housing
 - Differential cover to differential housing
- 5.3 From time to time components shall have MotorSport NZ official seals affixed at the discretion of the Series Scrutineer. A penalty will be imposed on competitors who do not have holes correctly drilled.
- 5.4 Competitors are advised to consult with the Series Scrutineer, prior to their first event, if any doubt exists to these requirements. If fixings are not predrilled a penalty as specified in the Series Articles may be applied.

- 5.5 The only seal recognised for the purpose of sealing components shall be a seal supplied and recorded by the Club. For very short-term sealing purposes a paint seal may be applied by the Series Scrutineer or other person so authorised by the Club.
- 5.6 Should a Competitor require permission to remove a seal for maintenance purposes, then it is essential they seek authorisation from the Series Scrutineer **prior** to the seal being broken. The Series Scrutineer reserves the right to have the sealed components checked for eligibility purposes. Seals may only be removed where authorised by the Series Scrutineer in accordance with the provisions of Appendix Two, Schedule A, Article 3.7 of the current MotorSport New Zealand Manual.
- 5.7 Penalties for breaking seals without prior authorisation shall be applied in accordance with the current MSNZ Manual.
- 5.8 The onus shall remain entirely with the Competitor to ensure that seals are maintained in accordance with these regulations.
- 5.9 The presence of a seal shall not protect the car from being subject to a protest, or from examination by Series Scrutineers.
- 5.10 Official Series Seals may be applied by the Series Scrutineer and/or a MotorSport NZ licensed Technical Officer to components and/or assemblies of components in compliance with Appendix Two Schedule A, Part One, Article 3.7. All seals shall be clearly detailed in the vehicles MotorSport NZ logbook.
- 5.11 Other seals may be applied by a Series official or an event official for judicial or scrutiny purposes.
- 5.12 Where vehicle components are sealed and the Driver or Entrant requires them to be removed for maintenance purposes, the Driver or Entrant shall give a minimum of three(3) days' notice of this requirement to the Series Scrutineer in writing. Where removal is required during a Series Round, verbal request can be made directly to the Series Scrutineer.
- 5.13 Where possible the Series Scrutineer will endeavour to make themselves available for the removal of seals at each event, but when removal is required outside of scheduled Series Rounds this service may be invoiced by the Club to the Driver or Entrant at the following rates:
- | | |
|--------------|--|
| Hourly Rate: | \$25.00 per hour (GST exclusive) |
| Travel Rate: | \$0.35 per km (GST exclusive) or as agreed by the Club Committee |

6. COACHWORK (BODYSHELL, VEHICLE EXTERIOR)

- 6.1 External body trim (decorations) e.g. side protection mouldings and front guard indicator assemblies may be removed. Holes, etc shall be repaired to a tradesman-like standard.
- 6.2 Additional fastening bolts may be added to the front and rear bumper fascia for the sole purpose of securing the bumper bars.
- 6.3 The original primary bonnet fasteners, and release mechanisms shall be removed. It is permitted to remove the original boot lid fasteners and release mechanisms. Alternative bonnet and boot lid fasteners shall be fitted in compliance with the current MSNZ Manual. Hinges shall remain and be operational as originally manufactured.
- 6.4 The attachment of any strengthening to, or seam welding of, the body or chassis or is prohibited.
- 6.5 The edges of the mudguard panels may be folded back if they protrude inside the wheel housing. The external shape of the mudguard panels shall not be altered. Plastic wheel splash guards may be removed.
- 6.6 The windscreen shall be of laminated glass. It may incorporate electric heating elements.

- 6.7 All body work including any subsequent repair of race day damage shall be to a tradesman-like standard and shall permit the vehicle to be presented in as near to original condition as possible.
- 6.8 **Cup Class**
- 6.8.1 All add-on body enhancements (spoilers, skirts, grilles, etc) are not permitted, regardless of whether they were fitted as factory or dealer options, save for the permitted *controlled component* body kit option as supplied through the Club. The vehicle silhouettes prior to the fitment of the *controlled component* body kit option shall remain as per the manufacturer's standard, unmodified base model.
- 6.9 **Trophy Class**
- 6.9.1 **Holden Commodore VT, VX, VY & VZ**
- (a) The vehicle shall be fitted with an SS or S pack front bumper fascia and boot lid wing as fitted and supplied by GM Holden, or an aftermarket replacement that retains the original external shape, dimensions and pitch.
- 6.9.2 **Ford Falcon AU**
- (a) The vehicle shall be fitted with either an AU XR6 front bumper fascia and boot lid wing as fitted to the AU XR6 model by Ford Australia, or an aftermarket replacement that retains the original external shape and dimensions OR the alternative front bumper fascia, side skirts and rear T wing as supplied through the Club.
- 6.10 Exterior appearance and dimensions shall be as originally manufactured. All lenses and lamps shall be of original type and appearance. It is permitted to interchange similar external panels between models where such panels are attached without modification to the fitted panels or surrounding bodywork, whilst retaining the integrity of the original model.
- 6.11 External transverse jack sockets may be fitted to the underside of the vehicle, finishing flush with the sill. Allowance for a lifting rod of a minimum 22mm and maximum 35mm diameter with a minimum length of 127mm shall be respected.

7. VEHICLE INTERIOR

- 7.1 The interior trim shall be complete as manufactured save that: floor coverings including underfelt and deadener, hood lining, arm rests, centre console, parcel shelf covering, internal lights, radio, central locking, pillar linings, sun visors, pinch weld mouldings, rubber door opening seals, spare wheel and jack may be removed. All controls and their functions shall remain as provided by the manufacturer.
- 7.2 It is permitted to remove all heater and air conditioning components.
- 7.3 The driver's seat shall be replaced by one complying with, and fitted in accordance with Schedule A Part One Article 4.7 Seating of the current MotorSport New Zealand Manual, all other seats shall be removed.
- 7.4 The steering wheel may be replaced by one with a minimum diameter of 330mm. Steering column locks which entail the use of a key shall be removed or rendered inoperative. It is permitted to install a quick-release steering wheel assembly. When a quick-release steering wheel assembly is installed, the original upper steering shaft (column) length shall be maintained (+/- 50mm). The quick-release steering wheel assembly adaptor shall not exceed 75mm in length.
- 7.5 A foot rest may be fitted to the left of the clutch pedal. A floor covering of anti-slip type may be fixed to the floor of the vehicle interior, forward of the driver's seat. Replacement pedal pads are permitted. A clutch and/or accelerator pedal stop may be fitted.

- 7.6 The use of a driver's window safety net fitted in compliance with the current MotorSport NZ Schedule A Part One Article 4.5 is mandatory. It is preferred that the window safety net be attached to the safety cage and/or body of the vehicle rather than the driver's door.
- 7.7 It is permitted to modify the moulded armrests in the original door trims to allow for the fitment of the safety cage. It is permitted to replace the original door trims with flat metal trim (eg. fabricated from sheet aluminium). The door trims must be fastened with screws and be readily removable.
- 7.8 It is permitted to relocate the interior door opening devices. The interior door opening mechanisms must remain functional.
- 7.9 It is permitted to install NACA style ventilation ducts in the rear door window apertures. Fitment is to be achieved whilst retaining the standard window glass and winding mechanism through lowering the window glass sufficiently to accommodate and secure the duct and surrounding insert. The ducts shall have the sole function of providing air into the cockpit.
- 7.10 It is permitted to remove the glass from all passenger doors including the drivers' door and replace with a LEXAN Polycarbonate alternative. Front and Rear windows must remain as laminated glass.
- 7.11 It is permitted to remove the door window opening and closing mechanisms from the passenger doors only. The drivers' door window opening and closing mechanism must remain operational.

8. SAFETY CAGE

- 8.1 A safety cage shall be constructed, installed and homologated in compliance with Schedule A Part One, Article 4.6 and Part Two, Articles 5 and 6 of the current MSNZ Manual.
- 8.2 Cup Class**
- 8.2.1 The safety cage configuration, dimensions and mounting shall be as detailed in the relevant diagrams in Appendix A of these regulations. This provides for the maximum tube members authorised.
- 8.2.2 The main rollbar (hoop) shall be positioned no more than the distance behind the centre-line of the 'B' post prescribed in diagram 1 in Appendix A for the relevant vehicle.
- 8.2.3 The backstays (braces) shall be positioned as per diagram 1 in Appendix A between the rear wheel arches of the bodyshell, not extending rearwards of the centre-line of the rear axle.
- 8.2.4 The front windscreen braces shall be no more than 330mm in length.
- 8.2.5 An attachment plate may be incorporated along the windscreen aperture section of the 'A' pillar to a maximum length of 200mm (per pillar).
- 8.2.6 A metal foot shall be welded to the sill / floor pan as described in diagram 2 in Appendix A for the relevant vehicle.
- 8.2.7 A cross shall be fitted between the backstays in accordance with diagram 5 in Appendix A.
- 8.2.8 Side intrusion bars shall be fitted in the form of a cross on both sides of the safety cage as per diagrams 6 and 7 of Appendix A. The intrusion bar cross (central intersection of bars) shall be boxed (excluding the top section) as per diagram 7. This boxing is mandatory for the driver's side and optional for the passenger's side.
- 8.2.9 Attachment to the bodyshell is only authorised at the six footing positions, the top of the transmission tunnel, the dashboard support, the 'A' pillar (maximum length of 200mm), and the sill bar to the sill (maximum of four 50mm lengths). The main rollbar (hoop) may be welded or bolted to the 'B' post location of the original upper seat belt location.

8.2.10 The dashboard and dashboard support may be modified locally for the sole purpose of accommodating the safety cage. Such modifications are to be finished to a tradesman-like standard.

8.2.11 It is permitted to add bracing for the sole purpose of mounting a driver's seat.

8.3 Trophy Class

8.3.1 For Trophy Class vehicles constructed new in New Zealand, the safety cage requirements prescribed under regulation 8.2 shall apply.

8.3.2 In addition to regulation 8.2.1 it is permitted to extend the safety cage forward of the front bulkhead, attaching the stays to the rear of the front suspension towers. These stays are permitted to be braced back to the bulkhead.

8.3.3 The main roll bar (hoop) shall be positioned no more than 200mm behind the centre-line of the 'B' post.

8.4 All existing safety cages homologated by MSNZ under Schedule A, prior to 31-05-2009, installed in cars which have a proven history of competition in a Super Six Saloons Race Series will be accepted as compliant with this Schedule until further notice. All such safety cages may not be modified from their homologation as originally issued by MSNZ unless prior written authorisation is granted by the Club and MSNZ.

8.5 All safety cage constructors are advised to seek any necessary clarification from the appointed Series Scrutineer (as detailed in the Series Articles) regarding the construction / fabrication of the safety cage to ensure compliance with this schedule is maintained.

9. SUSPENSION AND STEERING

9.1 General

9.1.1 The suspension components shall be of standard manufacture (and fitted to the respective vehicles in their original positions) unless specifically provided for in these regulations.

9.1.2 Suspension bushes and bump stops may be replaced with aftermarket items of elastomeric construction.

9.1.3 It is permitted to remove the original rubber spring insulators. Solid spacers of uniform section may be fitted between the springs and their unmodified mounting points to achieve a desired ride height, with a maximum spacer/s thickness of 30mm total on any one spring.

9.1.4 It is permitted to fit aftermarket suspension stabiliser bar link pins. It is permitted to remove or render the stabiliser bars and associated hardware inoperative.

9.1.5 A front strut brace may be fitted between the front suspension towers, attached by bolting only at the tops of the suspension towers.

9.1.6 It is permitted to fit *controlled component* adjustable front suspension tension rods.

9.1.7 Wheel alignment on the front wheels is free within the limits of the specified components, save that the maximum negative camber at each front wheel is 5°.

9.1.8 It is permitted to fit an oil cooler to the power steering system. It is permitted to replace the power steering hoses with those of adequate strength and quality. It is permitted to vent the power steering fluid reservoir into a catch tank.

9.1.9 Vehicle dimensions / weight limits

Model	VN/VP	EA/EB	VT/VX/VY/VZ	AU
Minimum ride height	100mm	100mm	100mm	90mm

Minimum racing weight	1,350kg	1,430kg	1,450kg	1,450kg
Maximum front track	1,780mm	1,875mm	1,900mm	1,854mm
Maximum rear track	1,760mm	1,820mm	1,846mm	1,825mm
Wheelbase	2,780mm	2,824mm	2,820mm	2,800mm

9.1.10 The vehicle ride height shall have at least 100mm ground clearance for any sprung component of the vehicle (excluding exhaust system) with the driver normally seated.

9.1.11 Ballast may be used to achieve the minimum weight requirements, and if used, shall be fitted in accordance with the current MSNZ Manual.

9.1.12 The maximum track dimensions shall be the distance between the outermost part of the walls of each tyre.

9.2 Cup Class

9.2.1 Holden Commodore VN & VP

- (a) It is permitted to strengthen the original Commodore panhard bar mounting bracket on the bodyshell as per Appendix B.
- (b) It is permitted to widen the front track by a maximum of 30mm. Any increase in the track measurement shall only be achieved by relocating the lower/inner control arm pivot point by an equal amount on both sides as per Appendix C.
- (c) The following *controlled components* shall be utilised in each vehicle. All such components shall be purchased through the Club and be identifiable by the applicable part number:

Component / Location	Part Number
Front Shock Absorber	9795 Pedders SportsRyder Cartridge
Rear Shock Absorber	9094 Pedders Gas SportsRyder
Front Spring	5623 Pedders Racing Coil
Rear Spring	2129 Pedders SportsRyder Coil
Front Swaybar	4803 Pedders Swaybar
Rear Swaybar	OEM 16mm or 19mm diameter
Panhard Bar	4633 Pedders Adjustable Panhard Rod
Strut Top	Pedders or Kmac Strut Top

9.2.2 Ford Falcon EA & EB

- (a) It is permitted to:
 - (i) Reposition the lower control arm inner pivot point on the sub-frame an equal amount on both sides, on the same horizontal plane as the original pivot points, and weld a washer to the relocated hole.
 - (ii) Install a recognised Falcon camber adjustment kit in accordance with standard after-market practice.
 - (iii) Fit an additional idler pulley to support the power steering pump drive belt. The pulley shall be mounted directly to the alternator belt adjustment bracket as per Appendix D.

- (b) The following *controlled components* shall be utilised in each vehicle. All such components shall be purchased through the Club and be identifiable by the applicable part number:

Component / Location	Part Number
Front Shock Absorber	9899 or 9934 Pedders Gas SportsRyder
Rear Shock Absorber	9080 Pedders Gas SportsRyder
Front Spring	5622 Pedders Racing Coil
Rear Spring	2181 Pedders SportsRyder Coil
Front Swaybar	4812 Pedders Swaybar
Strut Top	5800 Pedders Caster Camber Kit or Kmac

9.3 Trophy Class

9.3.1 Holden Commodore VT, VX, VY & VZ

- (a) The upper steering shaft (column) may be replaced with a Commodore VY upper steering shaft.
- (b) It is permitted to:
- (i) Reposition the lower control arm inner pivot point on the “K” frame an equal amount on both sides, on a horizontal plane in line with the centre of the original pivot points. The distance between the horizontal centre line of this pivot point and the upper mounting surface of the K frame to the chassis rail shall be 92mm (\pm 3mm), as per Dimension A of Appendix E.
 - (ii) Relocate the bolt holes on the front strut mounting perches to obtain the desired negative camber and ride height measurement. After achieving the desired measurement, it is required to weld a washer over any slotted hole to prevent movement.
 - (iii) Fit a front strut bearing retainer.
 - (iv) Shorten the rear shock absorber dust cover by a maximum of 120mm.
 - (v) Machine the top section of the front strut shaft to reduce its effective length by a maximum of 10mm, as per Appendix F.
- (c) The following *controlled components* shall be utilised in each vehicle. All such components shall be purchased through the Club and be identifiable by the applicable part number:

Component / Location	Part Number
Front Strut	9435 L&R Pedders Gas Ryder
Rear Shock Absorber	9195 or 9095 Pedders Gas Ryder
Front Spring	5601 Pedders Racing Coil
Rear Spring	SO108378VT King Springs Racing Coil

9.3.2 Ford Falcon AU

- (a) It is permitted to:
- (i) Reinforce the front stabiliser bar mounting brackets.
 - (ii) Relocate the front damper assembly lower mounting hole by a maximum of 20mm to achieve the desired ride height and weld a washer to the relocated hole.
 - (iii) Remove metal from the lower front shock absorber mounting to allow clearance of the suspension components.
- (b) Front suspension uprights shall be as fitted to the Falcon AU series 2 model (front mounted brake caliper).

- (c) The top inner camber kits are free save that they must utilise the original mounting points and respect the vertical height. The centre of the top wishbone pivot point on the camber kit may be lowered by 15mm from standard or be a minimum of 10mm and a maximum of 25mm from the centre of the mounting stud as per Appendix G of these regulations.
- (d) The following *controlled components* shall be utilised in each vehicle. All such components shall be purchased through the Club and be identifiable by the applicable part number:

Component / Location	Part Number
Front Strut	9434 L&R Pedders Gas Ryder
Rear Shock Absorber	9180 Pedders Gas Ryder
Front Spring	5626 Pedders Racing Coil
Rear Spring	2181 Pedders SportsRyder Coil

10. BRAKING SYSTEM

- 10.1** Brake pads are free. The friction material of the brake pads is free as is the method of attachment provided that the contact surface area of the pad is not greater than that supplied by the manufacturer of the calliper assembly. The maximum permitted thickness of the backing plate is 6mm. The retention of the pad assembly in the calliper shall be by the method prescribed by the manufacturer of the calliper assembly.
- 10.2** Original brake pipes and flexible hoses may be replaced by others of adequate strength and quality.
- 10.3** It is permitted to fit a residual line pressure valve to the braking system.
- 10.4** It is permitted to fit a variable brake pressure valve in the rear brake line. This valve may be mounted within reach of the driver whilst racing. Where such a valve has been fitted in accordance with these regulations, the master cylinder valve may be modified or removed. The rear brake line may be redirected to accomplish the fitment.
- 10.5** The handbrake and all associated components may be disconnected or removed.
- 10.6** The master cylinder may be replaced by one interchangeable with the standard master cylinder. The bore size and internal valving are free.
- 10.7** A reinforcing bracket for the sole purpose of reducing flexing may be fitted to the master cylinder.
- 10.8 Brake Ducting**
- 10.8.1** It is permitted to fit one flexible ducting pipe (maximum 100mm diameter) to carry air to each front and rear brake. All ducted air shall be for brake cooling only.
- 10.8.2** No apertures or modifications to the bodywork for the purpose of fitting air intake ducts are permitted, except those specifically provided for in these regulations.
- 10.8.3** Fittings at the exhaust end of the ducting pipe are free, subject to the only ~~no~~ modifications being made to other components being those required to provide attachment of the ducting pipe.
- 10.8.4** Rear brake rotor shields may be modified or removed for brake cooling. If removed, a brake hose support bracket shall be fitted.
- 10.9 Cup Class**
- 10.9.1** It is permitted to fit a *Controlled Component* pre-load spacer between the inner and outer front wheel bearings.
- 10.9.2** It is permitted to modify the front bumper for fitment of the *Controlled Component* air intake ducts, which shall be positioned as designated in Appendix H.

10.9.3 Holden Commodore VN & VP

- (a) The Commodore shall use the *Controlled Components* twin piston front caliper and *Controlled Components* 330mm slotted front rotors. The rear brakes shall be of standard Holden Commodore VN/VP manufacture and be fitted to the respective vehicles. Controlled front brake components are available in kit form through the Club. Kits include mounting brackets and bolts.

10.9.4 Ford Falcon EA & EB

- (a) The Falcon shall use the *Controlled Components* twin piston front caliper and *Controlled Components* 330mm directionally slotted front rotors in conjunction with the *Controlled Components* hub and spacer). The rear brakes shall be of standard Ford Falcon EA/EB manufacture and be fitted to the respective vehicles. Controlled front brake components are available in kit form. Kits include mounting brackets and bolts.
- (b) In order to fit the calliper and rotor to the Falcon, the front suspension uprights have to be modified. These *Controlled Component* modified uprights are only available through the Club. It is not permitted to use any unauthorised Falcon front suspension uprights.

10.10 Trophy Class

10.10.1 Front brake rotors shall be of ferrous material with a maximum diameter of 330mm and a maximum thickness of 32mm.

10.10.2 Brake rotor hats are free.

10.10.3 Anti-lock braking systems (ABS) shall be removed.

10.10.4 Holden Commodore VT, VX, VY & VZ

- (a) It is permitted to use any OEM, or direct replacement of, Holden Commodore twin piston front brake calipers or Wilwood front brake calipers (part numbers 120-13267-N (RH) and 120-13267-N (LH)).
- (b) It is permitted to modify the rear braking system with the fitment of 316mm x 18mm brake rotors and any Holden single-piston rear brake calipers (i.e., a caliper which was originally designed to be used on the rear). In order to fit the permitted rear brake modification, it is permitted to fit an aftermarket caliper mounting bracket.

10.10.5 Ford Falcon AU

- (a) It is permitted to use any OEM, or direct replacement of, Holden Commodore or Ford Falcon twin piston front brake calipers, PBR-C4 twin piston front brake calipers or Wilwood front brake calipers (part numbers 120-13267-N (RH) and 120-13267-N (LH)).
- (b) It is permitted to modify the rear braking system with the fitment of 328mm x 26mm brake rotors and Ford brake calipers as fitted to the Ford Territory (part numbers SX2K327A and SX2K328A).

11. ROAD WHEELS and TYRES

11.1 Only the following specification of tyres, known as the *Controlled Component* tyre for the Series, may be used and shall be fitted in accordance with the tyre manufacturer's recommendation (for the avoidance of doubt, tyres are not permitted to be rotated on the wheel in contradiction to the tyre manufacturer's recommendation).

(1) **Dry Tyre:** Nexen N'Fera SUR4G 235 45 R17

(2) **Wet Tyre:** Nexen N'Fera SUR4G 235 45 R17

All wet tyres used in this situation shall have a minimum tread depth of 3mm prior to the commencement of the qualifying session or race.

11.2 At the commencement of qualifying or racing the "pin hole" tread markers shall be visible across the width of the tyre and 80% of the circumference of the tyre.

- 11.3** The following modifications/treatments to tyres are specifically prohibited:
- 11.3.1** Filing, buffing, or any other disguising of the tyre sidewall.
 - 11.3.2** Hand-cutting of tread grooves.
 - 11.3.3** Tyre warmers, chemical treatments or any means of artificially enhancing tyre performance.
- 11.4** It is permitted to buff or hand trim the tread, provided that the profile of the tread pattern remains as manufactured.
- 11.5** Wheels are free save that they shall be 17" x 8" with a minimum weight of 8.50kg each, and when fitted to the vehicle shall comply with the vehicle track dimensions detailed in Regulation 9.1.9.
- 11.6** All four wheels fitted to the vehicle shall be of the same style (make & model) and size, including offset.
- 11.7** A metallic wheel spacer may be added behind each wheel in compliance with **Schedule A Part One Article 4.9** of the MotorSport NZ Manual.

12. FUEL and FUEL SYSTEM

12.1 Cup Class

- 12.1.1** The only fuel permitted is 98 RON unleaded petrol as available from retail service station pumps throughout New Zealand and complying with the specifications as detailed in **Schedule A Part One 3.9 and Part Two Article 3** of the current MotorSport NZ Manual.

12.2 Trophy Class

- 12.2.1** The only fuels permitted are:
- 98 RON unleaded petrol as available from retail service station pumps throughout New Zealand and complying with the specifications as detailed in **Schedule A Part One 3.9 and Part Two Article 3** of the current MotorSport NZ Manual.
 - E85 ethanol/petrol blend complying with the specifications as detailed in the current MSNZ Manual.
- 12.3** Additives of any kind, specification, chemical description or composition shall not be added to the fuel, nor may a blend of two or more fuels be used.
- 12.4** It is not permitted to artificially cool fuel.
- 12.5** To facilitate both fuel sampling and pressure testing, a *controlled component* "dry break" coupling (female coupling only) purchased through the Club shall be fitted to the fuel system under the bonnet.
- 12.6** Original equipment fuel injectors may be replaced by other interchangeable units.
- 12.7** Fuel pressure shall not exceed 400kPa.
- 12.8** Fuel tanks shall be either:
- 12.8.1** The standard fuel tank fitted in its original position which may be baffled or filled with anti-spray foam.
 - 12.8.2** It is permitted to replace the standard fuel tank with a safety fuel tank (fuel cell) fitted in compliance with **Schedule A Part One Article 4.12** of the current MotorSport NZ Manual provided that:
 - (a)** The location of fitment remains essentially the same as for the standard fuel tank.
 - (b)** The capacity of the safety fuel tank be declared to the Series Scrutineer.

- (c) Ballast to compensate for a lighter fuel load is to be fitted in compliance with Schedule A Part One Article 6.1 of the current MotorSport NZ Manual in the same general area (i.e. in the luggage compartment on the same side as the standard fuel tank was mounted). The amount of ballast to be added is calculated on the capacity of the safety fuel tank as follows:
- (i) For a capacity of more than 25 litres the amount of ballast to be added is 20kg.
 - (ii) For a capacity of less than 25 litres the amount of ballast to be added will be calculated on a case by case basis by the Club.

12.9 Fuel caps are free.

12.10 It is permitted to replace and relocate the factory fuel lines, filters and fuel pump. An inline metal cased fuel filter may be used.

12.11 It is permitted to fit one anti-surge fuel tank of 5.5 litre maximum capacity and one additional electric fuel pump in the rear of the vehicle. If the anti-surge tank and/or pump kit components are mounted inside the luggage compartment area, a fireproof and liquid-proof bulkhead shall separate the cockpit from the rear luggage compartment.

13. ELECTRICAL

13.1 A general circuit breaker shall be fitted in compliance with accordance with Schedule A Part One Article 5.4 (2) of the current MotorSport NZ Manual.

13.2 The location of the battery is free, provided that it meets the requirements of Schedule A Part One Article 5.5 of the current MotorSport NZ Manual. The maximum battery size shall be a size that can fit the standard battery tray for the vehicle.

13.3 It is permitted to replace the wiring loom provided that all essential electrical functions remain operational, including windscreen wipers, brake lights and rain lights. Fuses may be added to the electrical system.

13.4 It is permitted to remove the central locking components, radio, interior lights and other non-essential electrical functions, along with any non-functional electrical wiring, modules and connectors.

13.5 It is permitted to move the ignition mechanism and wiper/indicator stalks from the steering column and replace with alternative operating systems.

13.6 Supplementary switches and instruments in addition to those already supplied by the manufacturer may be fitted, provided that all original instruments and switches are visible and retained in their original positions.

13.7 An operational "HI-STOP" type brake light shall be fitted to the centre bottom of the rear screen. This shall be retained by mechanical fastening and not solely by adhesives.

13.8 It is permitted to install the *controlled component* rain light to the centre of the panel immediately above the number plate recess, or in the middle of the number plate recess.

13.9 A windscreen demister may be fitted.

14. ECU and IGNITION

14.1 The only ECU permitted is the *Controlled Component* sealed 4424 Stinger or the *Controlled Component* MoTeC 13130AJ as supplied through the Club.

14.2 The ECU shall be located in the front passenger area and be readily accessible for inspection.

14.3 The original ECU and connector plug in the vehicle wiring loom as fitted by the manufacturer shall be removed.

- 14.4** The maximum engine RPM shall be set by Engine Management Systems Australia (EMS), MoTeC or a person authorised by the Club for such purpose and not exceed the maximum parameters for each vehicle, set as follows:

Vehicle	Maximum Engine RPM
Holden Commodore VN & VP	5,500rpm
Ford Falcon EA & EB	5,500rpm
Holden Commodore VT, VX, VY & VZ	6,250rpm
Ford Falcon AU	5,800rpm

- 14.5** It is permitted to fit an ignition module supplied by EMS.
- 14.6** It is permitted to remove the MAP and MAF sensors and idle control motor. A blanking plate shall be fitted to the resulting apertures.

14.7 Cup Class

14.7.1 Holden Commodore VN & VP

- (a) It is permitted to use the coil pack assembly as fitted to the Series 2 engine.
- (b) It is permitted to fit a guard over the alternator for the sole purpose of safety.

14.7.2 Ford Falcon EA & EB

- (a) It is permitted to relocate the ignition coil within the engine compartment.

14.8 Trophy Class

14.8.1 Ford Falcon AU

- (a) It is permitted to relocate the ignition coil packs within the engine compartment.

15. DATA DEVICES

- 15.1** It is permitted to fit a data storage device, including a multi-display dash with only ability to store vehicle data. Data logging shall be limited to lap timing, drive line and engine function only.
- 15.2** Any device which has the capability of outputting any signal or data to the vehicle ECU, or that is capable of altering the vehicle engine functions in any way, irrespective of whether it is being used or not will be considered to be an ECU and therefore in breach of these regulations. Any such unit is specifically not permitted in the vehicle during competition. The data storage device shall be mounted in a visually accessible position.
- 15.3** The software for the data storage device shall not show any pin allocations set up to read sensors other than those permitted.
- 15.4** The use of any form of real time telemetry or the transmission of any data other than a lap trigger signal to or from the vehicle is specifically prohibited.
- 15.5** A lap timing device which has the sole function of timing each lap or laps is permitted.

16. ENGINE SPECIFICATIONS

16.1 General

- 16.1.1** Engine mounts may be replaced with commercially available items that retain the OEM engine position and angle.
- 16.1.2** It is permitted to fit extra engine breathers, but all breathers must discharge to a catch tank which is vented to the atmosphere.
- 16.1.3** The use of any substance which leaves a metallic or ceramic coating on the cylinder heads, combustion chambers, engine block, valves, inlet ports, inlet manifolds, or pistons is prohibited.

16.1.4 Lubrication

- (a) The oil pressure relief valve spring may be shimmed.
- (b) Baffling of the sump is permitted, save that the external appearance of the sump is as supplied by the manufacturer as standard.
- (c) It is permitted to fit an engine oil cooler provided that the bodywork is not altered for the purpose of its fitment, and it is mounted within the confines of the standard bodywork.

16.1.5 For the 2023-24 Series the Club authorised persons for the purpose of piston inspection are:

North Island

Grady Homewood
 M: 09 294 6001
 E: office@hitechmotorsport.co.nz

South Island

Russell Keeler
 M: 027 436 8685
 E: rdkeeler@xtra.co.nz

16.2 Cup Class

16.2.1 Holden Commodore VN & VP

- (a) It is permitted to use either the Series 1 or Series 2 Holden V6 engine as fitted to the Commodore VN Series 1 and Series 2 and Commodore VP Series 1. Engines shall be used in their entirety with no interchanging of components permitted, except as specifically authorised in these regulations.
- (b) Cylinder Heads
 - (i) The cylinder heads shall remain completely standard except as specifically authorised in these regulations.
 - (ii) The maximum valve head diameter permitted is:
 - Inlet valves 43.44mm.
 - Exhaust valves 37.97mm.
 - (iii) The valves' seat faces may be re-cut but a 45 degree valve seat with a minimum width of 2.50mm shall be retained.
 - (iv) It is permitted to machine the valve seats in the cylinder heads at 45 degrees with the overcut angles/radii being free. The distance from the outer edge of the valve to the closest point of the combustion chamber shall not exceed 6mm.
 - (v) It is permitted to reclaim the valve seats as per the manufacturer's specifications, including through the use of a seat insert.
 - (vi) It is permitted to use K-Line 11/32" valve guides.
 - (vii) It is permitted to machine the cylinder head face to obtain a minimum combustion chamber volume as specified in the table below. Angle milling is not permitted.

Piston / Part Number	Cylinder Head	Piston Bowl
ACL 3800	36.00cc	25.00cc
ACL 9380	37.50cc	23.50cc
Precision PHO38006040MMS	37.50cc	23.50cc

- (viii) Throating or machining of the cylinder head ports is permitted only between the valve seat to a depth no greater than the top of the untouched valve guide boss casting using a parallel or tapered cutter with the centre-line of the valve guide being the axis of rotation of the cutter. Any taper may only be diminishing in size from the valve seat at its narrowest point to the valve guide boss casting.
 - (ix) Machining of the spring seat, valve guide boss, and rocker pedestal boss is not permitted.
 - (x) The use of hardened or machined collets and retainers is permitted.
 - (xi) Valve springs are free subject to there being a maximum of two springs per valve. It is permitted to fit shims under the valve springs.
 - (xii) The cylinder head gaskets shall be of a standard configuration, type and dimensions for the model and readily available as a standard replacement part with a minimum thickness of 0.95mm.
- (c) Valve Train
- (i) Only standard GMH pushrods are permitted (Part No. 25532501 or 24504923).
 - (ii) It is permitted to shim the rocker arm pedestals to obtain the correct tappet settings.
- (d) Camshaft
- (i) The camshaft is a *Controlled Component* and shall be supplied and logged by the Club's nominated control component agent, being KiwiCams prior to 30 June 2013, and Crow Cams from 1 July 2013.
 - (ii) The *Controlled Component* supplier shall either supply a new camshaft or re-profile a customer's unit to the control specification.
 - (iii) The camshaft shall be compliance checked by the Club's nominated control component agent, being Crow Cams.
 - (iv) It is the Competitors sole responsibility to ensure compliance with regulation (ii) above.
 - (v) Camshaft bearings Part No. 4C5106 Std or 010", or ISC19549 oversize back.
 - (vi) It is permitted to remove the balance shaft and gears.
 - (vii) The timing chain and gears are free.
 - (viii) The camshaft phase angle in relation to the crankshaft is free.
- (e) Crankshaft and Connecting Rods
- (i) The crankshaft journals may be reground a maximum undersize of 1.00mm with a maximum stroke of 86.36mm with a tolerance of +/- 0.25mm.
 - (ii) The connecting rods may be resized and machined to provide additional side clearance.
 - (iii) Main and connecting rod bearings are free save that they must maintain the original external dimensions.
- (f) Balancing
- (i) All rotating and reciprocating components may be balanced by the removal of metal only from the locations so provided by the manufacturer.
 - (ii) Piston balancing shall be achieved by removal of metal from the underside of the piston only.
 - (iii) The minimum weight of each piston and gudgeon pin shall be 544g.
 - (iv) The connecting rod minimum weight shall be 640g.
 - (v) The crankshaft minimum weight shall be 16.00kg bare (VN) and 15.50kg bare (VP).
 - (vi) The flywheel may be machined on the driven face only, and be balanced to a minimum weight of 9.50 kg (VN) or 10.00 kg (VP).

- (vii) It is permitted to dowel the flywheel to the crankshaft.
 - (viii) A replacement harmonic balancer of similar materials, construction, design and dimensions may be used. The minimum harmonic balancer weight shall be 3.200 kg.
- (g) Intake Manifold**
- (i) The intake manifold shall remain completely standard except as specifically authorised in these regulations.
 - (ii) The intake manifold may be glass bead blasted.
 - (iii) It may be machined on the cylinder head and block mating faces to obtain correct fitment to the engine.
 - (iv) Match porting of the inlet manifold ports for a maximum distance of 6mm from each left and right hand face is permitted, as per Appendix I.
 - (v) No other hand or machine finishing is permitted.
 - (vi) The original air cleaner box shall be removed and replaced with a cone-type replacement air element attached directly to the unmodified front snorkel tube mounted in its original location. The PVC system shall be removed, and the resulting holes in the inlet manifold and throttle body shall be mechanically sealed.
- (h) Engine Block**
- (i) The engine block may be re-bored to a maximum oversize of 1.00mm.
 - (ii) The only pistons permissible shall be ACL/Mahle Part No. 3800 in Std, 020" or 040", or ACL/Mahle Part No. 9380 in Std, 020" or 040" or Precision Parts Australia Part no. PHO38006040MMS.
 - (iii) There shall be two compression rings and a segmented oil ring on each piston.
 - (iv) The piston rings shall have conventional gaps. Gapless piston rings are not permitted.
 - (v) The engine block face may be machined in a plane perpendicular to the cylinder bores. The pistons shall not protrude from the engine block face at TDC.
 - (vi) For the sole purpose of achieving the desired deck height it is permissible to machine the tops of up to five(5) pistons, provided that the minimum weight, original profile and bowl volume are maintained. The part number shall remain on at least one(1) piston.
- (i) It is permitted to fit an external timing pointer to the timing chain cover.
 - (j) It is permitted to slot the crank sensor angle to permit timing adjustment.

16.2.2 Ford Falcon EA & EB

- (a)** It is only permitted to use the Ford 3.9 litre Multi-point Electronic Fuel Injected engine as fitted to the Falcon EA and EB Series 1.
- (b) Cylinder Head**
 - (i) The cylinder head shall remain completely standard except as specifically authorised in these regulations.
 - (ii) The following valve dimensions shall be respected:
 - Maximum inlet valve head diameter: 47.00mm.
 - Maximum exhaust valve head diameter: 39.00mm.
 - Minimum valve guide total length: 62.23mm
 - Maximum valve guide protrusion above guide boss: 19.05mm
 - (iii) The valves' seat faces may be re-cut but a 45 degree valve seat with a minimum width of 2.50mm shall be retained.
 - (iv) It is permitted to machine the valve seats in the cylinder head at 45 degrees with the overcut and undercut angles/radii being free. The distance from the outer edge of the valve to the closest point of the combustion chamber shall not exceed 2.50mm.

- (v) It is permitted to reclaim the valve seats as per the manufacturer's specifications, including through the use of a seat insert.
- (vi) It is permitted to use K-Line valve guides.
- (vii) It is permitted to machine the cylinder head face to obtain a minimum combustion chamber volume as specified in the table below. Angle milling is not permitted.

Piston / Part Number	Cylinder Head	Piston Bowl
ACL 6MKRY2809	55.00cc	15.00cc
ACL 6MKRY3900	55.00cc	15.00cc
ACL 6MKRY9390	57.00cc	11.00cc
Precision PFO39006040MMS	37.50cc	11.00cc
SCRANZ <i>Controlled Component</i>	TBA	TBA

- (viii) Throating or machining of the cylinder head ports is permitted only between the valve seat to a depth no greater than the top of the untouched valve guide boss casting using a parallel or tapered cutter with the centre-line of the valve guide being the axis of rotation of the cutter. Any taper may only be diminishing in size from the valve seat at its narrowest point to the valve guide boss casting.
 - (ix) Machining of the spring seat, valve guide boss, and rocker pedestal boss is not permitted.
 - (x) The use of hardened or machined collets and retainers is permitted.
 - (xi) Valve springs are free subject to there being a maximum of two springs per valve. It is permitted to fit shims under the valve springs.
 - (xii) The cylinder head gaskets shall be of a standard configuration, type and dimensions for the model and readily available as a standard replacement part with a minimum thickness of 0.70mm.
- (c) Camshaft
- (i) The camshaft is a *Controlled Component* and shall be supplied and logged by the Club's nominated control component agent, being KiwiCams prior to 30 June 2013, and Crow Cams from 1 July 2013.
 - (ii) The Controlled Component supplier shall either supply a new camshaft or re-profile a customer's unit to the control specification.
 - (iii) The camshaft shall be compliance checked by the Club's nominated control component agent, being Crow Cams.
 - (iv) It is the Competitors sole responsibility to ensure compliance with regulation (ii) above.
 - (v) The timing chain and gears are free.
 - (vi) The camshaft phase angle in relation to the crankshaft is free.
- (d) Crankshaft and Connecting Rods
- (i) The crankshaft journals may be reground to a maximum 1.00mm undersize with a maximum stroke of 99.31mm with a tolerance of +/- 0.25mm.
 - (ii) The connecting rods may be resized and machined to provide additional side clearance.
 - (iii) Main and connecting rod bearings are free save that they must maintain the original external dimensions.
- (e) Balancing
- (i) All rotating and reciprocating components may be balanced by the removal of metal only from the locations so provided by the manufacturer.

- (ii) Piston balancing shall be achieved by removal of metal from the underside of the piston only.
- (iii) The minimum weight of each piston and gudgeon pin shall be:

Piston / Part Number	Minimum Weight
ACL 6MKRY2809	600g
ACL 6MKRY3900	562g
ACL 6MKRY9390	550g
Precision PFO39006040MMS	558g
SCRANZ <i>Controlled Component</i>	TBA

- (iv) The connecting rod minimum weight shall be 610g.
 - (v) The crankshaft minimum weight shall be 25.75kg bare.
 - (vi) The flywheel may be machined on the driven face only, and be balanced to a minimum weight of 11.00kg.
 - (vii) It is permitted to dowel the flywheel to the crankshaft.
 - (viii) A replacement harmonic balancer of similar materials, construction, design and dimensions may be used. The minimum harmonic balancer weight shall be 4.40kg.
- (f) Intake Manifold
- (i) The intake manifold shall be Ford part/casting number 87DA9425. The intake manifold shall remain completely original except as specifically authorised in these regulations.
 - (ii) The intake manifold may be glass bead blasted.
 - (iii) It may be machined on the cylinder head mating face to obtain correct fitment to the engine.
 - (iv) Match porting of the inlet manifold ports for a maximum distance of 6mm from the mounting face is permitted, as per Appendix J.
 - (v) No other hand or machine finishing is permitted.
 - (vi) The original air cleaner box shall be removed and replaced with a cone-type replacement air element attached directly to the unmodified front snorkel tube. A support bracket attached to a tube of maximum length of 100mm may be used to connect the air element to the tube.
- (g) Engine Block
- (i) The engine block may be rebored to a maximum oversize of 1.00mm.
 - (ii) The only pistons permissible shall be ACL Part No. 6MRKY2809, 6MRKY 3900 or 6MRKY 9390 Std, 020" or 040" or Precision Parts Australia Part no. PFO39006040MMS or the *Controlled Component* pistons as supplied through the Club. *Controlled component* pistons will be supplied with an identification marking separate to the inscribed part number to allow for authorised machining permitted under regulation (vi).
 - (iii) There shall be two compression rings and a segmented oil ring on each piston.
 - (iv) The piston rings shall have conventional gaps. Gapless piston rings are not permitted.
 - (v) The engine block face may be machined in a plane perpendicular to the cylinder bores. The pistons shall not protrude from the engine block face at TDC.

- (vi) For the sole purpose of achieving the desired deck height it is permissible to machine the tops of all six(6) pistons, provided that the minimum weight, original profile and bowl volumes are maintained. The part number shall remain on at least one(1) piston if up to five(5) pistons have been machined. Where all six(6) pistons are to be machined, the pistons shall be inspected by a Club authorised person prior to machining, unless the pistons are *Controlled Component* pistons and were supplied with an identification marking separate to the inscribed part number. The Club authorised person will inscribe the pistons as having been inspected.
- (vii) It is permitted to drill a 12mm hole through the rubber section of the engine mounts and fit a 12mm bolt with washers and a lock nut for the purpose of restricting the amount of stretching the rubber is subjected to.

16.3 Trophy Class

16.3.1 Holden Commodore VT, VX, VY & VZ

(a) The only permitted engine is the V6 Ecotec engine as fitted to the Commodore VT.

(b) Cylinder Heads

- (i) The cylinder heads shall remain completely standard except as specifically authorised in these regulations.
- (ii) The maximum valve head diameter permitted is:
 - Inlet valves 45.70mm.
 - Exhaust valves 38.60mm.
- (iii) It is permitted to machine the valve seats in the cylinder heads at 45° with the overcut/ undercut angles/radii being free. It is permitted to reclaim the valve seats as per the manufacturer's specifications, including through the use of a seat insert.
- (iv) It is permitted to machine the top of the valve guides to a minimum height of 20mm above the spring seat.
- (v) It is permitted to machine the ports from the valve seat to the untouched valve guide boss with the largest diameter at the valve seat. All machine work must be concentric with the centre line of the original valve guide.
- (vi) It is permitted to machine the cylinder head face parallel to the original surface to obtain a minimum combustion chamber volume as specified in the table below.

Piston / Part Number	Cylinder Head
ACL/Nason 6MKRY3802	50.00cc
Precision PHO3800L6040MMS	50.00cc
ACL/Nason 6MKRY9381S	54.00cc

- (vii) The use of hardened or machined valve collets and retainers is permitted.
 - (viii) The valve springs are free subject to there being a maximum of two springs per valve. It is permitted to fit shims under the valve springs.
 - (ix) It is permitted to machine the valve spring seats to obtain the correct valve spring installed height. It is permitted to de-burr the valve spring seats locally after machining, provided it is to industry standards. Other hand or mechanical finishing of the valve spring seats is not permitted.
 - (x) Cylinder head stud fasteners may replace cylinder head bolts.
 - (xi) The cylinder head gaskets shall be of a standard configuration, type and dimensions for the model and readily available as a standard replacement part with a minimum thickness of 0.95mm.
- (c) Valve Train
- (i) It is permitted to shim the rocker arm pedestals to obtain the correct tappet settings.

- (d) Camshaft**
- (i)** The only Camshaft permitted shall be Crow Cams part number TASCCO3800 or Clive Cams partnumber VTSSTC3800. Each Camshaft shall match the Crow Cams cam doctor report for that specific Camshaft.
 - (ii)** It is permitted to remove the internal balance shaft and gears, whereupon the rear balance shaft bearing oil supply hole may be blocked.
 - (iii)** The timing chain and gears are free.
 - (iv)** The Camshaft phase angle in relation to the crankshaft is free.
- (e) Crankshaft and Connecting Rods**
- (i)** The crankshaft journals may be reground a maximum of 1.0mm undersize, with a maximumstroke of 86.4mm.
 - (ii)** The connecting rods may be re-sized and machined to provide additional side clearance and to attain the correct piston height.
 - (iii)** The connecting rods may be replaced with part number 29FGFECAPM as supplied by Spool.
 - (iv)** Localised machining is authorised to facilitate the use of replacement rod bolts.
 - (v)** Shot peening treatment of connecting rods is permitted.
 - (vi)** Main and connecting rod bearings are free save that they must maintain the original external dimensions.
- (f) Balancing**
- (i)** All rotating and reciprocating components may be balanced by the removal of metal only from the locations so provided by the manufacturer.
 - (ii)** Piston balancing will be achieved by removal of metal from the underside of the piston only.
 - (iii)** The minimum weight of each piston and gudgeon pin shall be 474g.
 - (iv)** The connecting rod minimum weight shall be 610g. The minimum weight for connecting rods supplied by Spool (part number 29FGFECAPM) is 615g.
 - (v)** The crankshaft minimum weight shall be 15.20kg.
 - (vi)** Only the specified flywheel as supplied by Adelaide Clutch Service (part number FGM112C) is permitted. The flywheel may be machined on the friction surface only, and balanced to a minimum weight of 9.50kg.
 - (vii)** It is permitted to dowel the flywheel to the crankshaft.
 - (viii)** The minimum torsional damper weight shall be 3.50kg.
 - (ix)** It is permitted to use a Powerbond torsional damper (harmonic balancer).
- (g) Intake Manifold**
- (i)** The intake manifold shall remain completely original except as specifically authorised in these regulations.
 - (ii)** The intake manifold may be glass bead blasted.
 - (iii)** It may be machined on the cylinder head and blockmating faces to obtain correct fitment to the engine.
 - (iv)** Match porting of the inlet manifold ports for a maximum distance of 6mm from each left and righthand face is permitted, as per Appendix I of these regulations.

- (v) The original air cleaner box shall be removed and replaced with a cone-type replacement air element. The element shall be attached directly to the controlled air intake tube as supplied by Pacemaker (part number 5100). It is permitted to remove the inlet manifold mounting lug to obtain correct fitment of the intake tube. It is permitted to fit the air temperature sensor to the Pacemaker tube. The original air flow meter shall be removed and any device, bracket or component used to enclose or partly enclose the air intake element is prohibited.
 - (vi) The PCV system shall be removed, and the resulting holes in the inlet manifold and throttle body shall be mechanically sealed.
- (h) Engine Block
- (i) The engine block may be re-bored to a maximum oversize of 1.00mm.
 - (ii) The only pistons permissible shall be ACL/Nason part number 6MKRY3802 or 6MKRY9381S or Precision Parts Australia part number PHO3800L6040MMS.
 - (iii) There shall be two compression rings and a segmented oil ring on each piston.
 - (iv) Gapless piston rings are not permitted.
 - (v) The piston ring gaps may be adjusted, however the ends of each compression ring shall be parallel to the centre line of the cylinder bore.
 - (vi) The engine block face may be machined in a plane perpendicular to the cylinder bores. The 6MKRY93802 and PHO3800L6040MMS pistons may protrude above the block face by a maximum of 0.25mm from the engine block face at TDC. The 6MKRY9381 pistons shall not protrude above the block face at TDC.
 - (vii) For the sole purpose of achieving equal piston deck heights, it is permitted to machine a minimal amount of material from the top surface (crown) of any four (4) pistons per engine.
- (i) It is permitted to fit an external timing pointer to the timing chain cover.

16.3.2 Ford Falcon AU

- (a) The only permitted engine is the Ford 4.0 litre Multi-point Electronic Fuel Injected engine as fitted to the Ford Falcon AU.
- (b) Cylinder Head
 - (i) The cylinder head shall remain completely standard except as specifically authorised in these regulations.
 - (ii) The maximum valve head diameter permitted is:
 - Inlet valves 47.00mm.
 - Exhaust valves 41.00mm.
 - (iii) The valves' seat faces shall be re-cut at 45 degrees. Back cutting of the valves is permitted.
 - (iv) It is permitted to machine the valve seats in the cylinder head at 45 degrees with the overcut and undercut angles/radii being free.
 - (v) It is permitted to reclaim the valve seats as per the manufacturer's specifications.
 - (vi) It is permitted to machine the ports from the valve seat to the untouched valve guide boss with the largest diameter at the valve seat.
 - (vii) All machine work shall be concentric with the centre line of the original valve guide.

- (viii) It is permitted to machine the cylinder head face to obtain a minimum combustion chamber volume as specified in the table below.

Piston / Part Number	Cylinder Head
ACL 6MKRY4002	50.00cc
ACL 6MKRY9414S	57.00cc
Precision PFO3986L6040MMS	57.00cc

- (ix) It is permitted to fly cut the 6MKRY4002 piston to facilitate exhaust valve clearance.
- (x) Machining of the head face is permitted provided it is parallel to the original surface, (i.e. angle milling is not permitted).
- (xi) The use of hardened and/or machined collets and retainers is permitted.
- (xii) Valve springs are free subject to there being a maximum of two springs per valve. It is permitted to fit shims under the valve springs.
- (xiii) It is permitted to machine the valve spring seats to obtain the correct valve spring installed height. It is permitted to de-burr the valve spring seats locally after machining, provided it is to industry standards. Other hand or mechanical finishing of the valve spring seats is prohibited.
- (xiv) Machining of the valve guide boss, and rocker pedestal boss is not permitted.
- (xv) Cylinder head bolts may be replaced with cylinder head stud fasteners.
- (xvi) The cylinder head gaskets shall be of a standard configuration, type and dimensions for the model and readily available as a standard replacement part with a minimum thickness of 0.70mm.
- (c) Camshaft
- (i) The only camshaft permitted shall be Crow Cams part number TASCCO3900AU or Clive Cams part number SSTC4000.
- (ii) Each camshaft shall match the Crow Cams cam doctor report for that specific camshaft.
- (iii) It is the Competitors sole responsibility to ensure compliance with regulation (ii) above.
- (iv) The timing chain and gears are free.
- (v) The camshaft phase angle in relation to the crankshaft is free.
- (d) Crankshaft and Connecting Rods
- (i) The crankshaft may be reground to a maximum stroke of 99.30mm.
- (ii) The connecting rods may be resized and machined to provide additional side clearance and to attain the correct piston height.
- (iii) Localised machining is permitted to facilitate the use of replacement rod bolts.
- (iv) Main and connecting rod bearings are free save that they must maintain the original external dimensions.
- (e) Balancing
- (i) All rotating and reciprocating components may be balanced by the removal of metal only from the locations so provided by the manufacturer.
- (ii) Piston balancing shall be achieved by removal of metal from the underside of the piston only.
- (iii) The minimum weight of each piston and gudgeon pin shall be 499g.
- (iv) The connecting rod minimum weight shall be 615grams.
- (v) The crankshaft minimum weight shall be 29.40kg bare.

- (vi) The flywheel may be machined on the driven (friction) face only, and be balanced to a minimum weight of 9.10kg.
 - (vii) It is permitted to use an aftermarket flywheel as supplied by Adelaide Clutch Service (part number FFD112C).
 - (viii) It is permitted to dowel the flywheel to the crankshaft.
 - (ix) The minimum torsional damper weight shall be 4.30kg.
 - (x) A replacement harmonic balancer of similar materials, construction, design and dimensions may be used.
- (f) Intake Manifold
- (i) The intake manifold shall remain completely standard except as specifically authorised in these regulations.
 - (ii) The intake manifold may be glass bead blasted.
 - (iii) It may be machined on the cylinder head mating face to obtain correct fitment to the engine.
 - (iv) Match porting of the inlet manifold ports for a maximum distance of 6mm from the mounting face is permitted, as per Appendix J.
 - (v) The original air cleaner box shall be removed and replaced with a cone-type replacement air element attached directly to controlled air intake tube as supplied by Pacemaker (part number 4100AU).
 - (vi) It is permitted to remove the intake manifold mounting lug to obtain correct fitment of the intake tube. Any device, bracket or component used to enclose or partly enclose the air intake element is prohibited.
 - (vii) It is permitted to fit an after-market vacuum tank.
- (g) Engine Block
- (i) The engine block may be re-bored to a maximum oversize of 1.00mm.
 - (ii) The only pistons permissible shall be ACL/Nason part number 6MKRY4002 or 6MKRY9414S or Precision Parts Australia part number PFO3986L6040MMS.
 - (iii) There shall be two compression rings and a segmented oil ring on each piston.
 - (iv) Gapless piston rings are not permitted.
 - (v) The piston ring gaps may be adjusted, however the ends of each compression ring shall be parallel to the centre line of the cylinder bore.
 - (vi) The engine block face may be machined in a plane perpendicular to the cylinder bores. The pistons shall not protrude from the engine block face at TDC.
 - (vii) For the sole purpose of achieving the desired deck height it is permissible to machine the tops of up to five(5) pistons, provided that the minimum weight, original profile and bowl volumes are maintained. The part number shall remain on at least one(1) piston.
 - (viii) It is permitted to fit additional crankcase breathers but all breathers must discharge to a catch tank that is vented to the atmosphere.
 - (ix) It is permitted to drill a 12mm hole through the rubber section of the engine mounts and fit a 12mm bolt with washers and a lock nut for the purpose of restricting the amount of stretching the rubber is subjected to.

17. EXHAUST SYSTEM

17.1 General

17.1.1 It is permitted to modify locally, but not cut, the pinch weld flanges under the sill panel to facilitate the exit of the exhaust.

17.2 Cup Class

17.2.1 Cup Class vehicles shall use the *Controlled Component* exhaust system relevant to the respective vehicle.

17.2.2 The rear mounting bracket may be modified but not moved from its original position for the purpose of achieving a satisfactory fit and desired ground clearance.

17.2.3 It is permitted to effect repairs to the exhaust system provided the system profile is retained. Any alteration to the profile will be considered to be an unauthorised modification and penalised accordingly.

17.3 Trophy Class

17.3.1 The exhaust system is free from the exit of the cylinder head.

17.3.2 The exhaust system may be coated with materials other than paint (eg ceramic or high temperature coatings).

17.3.3 It is permitted to raise the rear passenger footwell on one side of the vehicle only to a maximum vertical height of 75mm and a maximum width of 300mm to accommodate the muffler. Such modification shall be fully welded to the remaining floor pan, which may extend into the underside of the rocker panel box section by no more than 30mm deep by 300mm wide cut out of the underside of the rocker and shall serve no purpose other than to accommodate the muffler.

17.3.4 It is permitted to add additional exhaust hangers for the sole purpose of mounting the exhaust.

18. COOLING SYSTEM

18.1 Engine

18.1.1 It is permitted to remove the original fan and fit a replacement electric radiator fan.

18.1.2 The fan shroud may be removed.

18.1.3 The thermostat is free as is the control system of the fan.

18.1.4 The original radiator may be replaced provided that the front plane of the radiator remains in the same location as the original, and that no modifications are carried out for its fitment. The radiator design, construction and fitment shall serve no purpose other than to cool the engine coolant.

18.1.5 A protective mesh screen may be fitted in front of the radiator.

18.1.6 A water filter may be fitted to the top radiator hose.

18.1.7 It is permitted to replace the original plastic radiator header tank with another of the same or smaller capacity. The replacement tank shall be mounted using the original mounting points.

18.1.8 It is permitted to fit radiator air ducting to the front of the radiator to aid engine cooling, provided that the bodywork is not altered for the purpose of its fitment, nor may it be fitted outside the confines of the standard bodywork. The ducting shall serve no other purpose than radiator coolant cooling.

18.2 Transmission

- 18.2.1** It is permitted to fit a transmission lubricant cooler, filter and pump. The cooler, filter and pump shall be fitted beneath the vehicle in the rear seat-well area as per Appendix K and be utilised only for the cooling of the gearbox lubricant.
- 18.2.2** It is permitted to drill and tap a thread into the transmission casing to accommodate the cooler return line as per Appendix L.

19. CLUTCH

19.1 General

- 19.1.1** A circular hole of 50mm diameter shall be made in the bottom of the bell housing to facilitate inspection of the clutch assembly and flywheel.

19.2 Cup Class

- 19.2.1** The clutch assembly shall remain as a single driven plate clutch assembly to the same dimensions as fitted by the manufacturer.
- 19.2.2** It is permitted to fit a 'paddle' or 'button' style clutch, provided regulation 19.2.1 above is respected.
- 19.2.3** The clutch assembly shall utilise the original mounting points.

19.3 Trophy Class

- 19.3.1** The clutch assembly may be replaced with authorised parts as listed under regulation 4.1.
- 19.3.2** The pressure plate assembly cover shall be of steel construction.
- 19.3.3** The clutch assembly shall remain as a single driven plate clutch assembly.
- 19.3.4** The clutch driven plate shall have a minimum diameter of 240mm.
- 19.3.5 Holden Commodore VT, VX, VY & VZ**

- (a)** It is permitted to shorten the front section of the tail shaft, or utilise the front section of a Commodore VT V8 automatic tail shaft to obtain the correct fitment to the T5 manual transmission.
- (b)** It is permitted to elongate the tail shaft centre bearing mounting bolt holes to facilitate the correct fitment of the tail shaft.
- (c)** It is permitted to replace the Commodore VT front tail shaft yoke with the yoke suited to the T5 manual transmission as fitted to the Commodore VN & VP models.

20. TRANSMISSION

20.1 General

- 20.1.1** It is permitted to replace the original rear countershaft bearing retainer with an aftermarket unit.
- 20.1.2** It is permitted to carry out local modification of the gearbox casing to allow the fitment of alternate bearings.
- 20.1.3** Internal gearbox components are free provided that they shall perform the original operation of the gearbox (i.e. synchromesh operation for the Borg-Warner T5 and T50D).
- 20.1.4** Dog tooth engagement is not permitted.
- 20.1.5** Components may be stress relieved by shot peening and/or other industry recognised methods.

- 20.1.6** The breathers for the gearbox may have extensions fitted by way of a length of tubing.
- 20.1.7** It is permitted to fit an aftermarket gear shifter provided that the original shift pattern is retained. The gear change lever, defined as the mechanism from the top of the gear knob to the bottom of the actuating 'knob' including the fastening plate, is free, save that it only serves as a gear change lever, and it shall be attached in the original manner.
- 20.1.8** It is permitted to remove the gearbox rear counterbalancing weight.

20.2 Cup Class

20.2.1 Commodore VN & VP

- (a) Only the Borg-Warner T5 manual five-speed gearbox may be used.

20.2.2 Falcon EA & EB

- (a) Only the Borg-Warner T50D manual five-speed gearbox may be used.

20.2.3 The only gearbox ratios permitted are as specified in the table below:

Gear	Commodore VN & VP	Falcon EA & EB (Option 1)	Falcon EA & EB (Option 2)
1 st	3.25:1	3.25:1	3.50:1
2 nd	1.99:1	1.99:1	2.14:1
3 rd	1.29:1	1.29:1	1.39:1
4 th	1.00:1	1.00:1	1.00:1
5 th	0.72:1 or 0.83:1	0.72:1 or 0.78:1 or 0.83:1	0.72:1 or 0.78:1 or 0.83:1
Reverse	3.15:1	3.39:1	3.39:1

20.3 Trophy Class

20.3.1 Commodore VT, VX, VY & VZ

- (a) Only the Borg-Warner T5 manual five-speed or the Tremec manual six-speed gearbox may be used.
- (b) It is permitted to modify the rear transmission mounting and cross-member, and the gear change aperture in the floor pan to facilitate the fitment of the T5 manual transmission.

20.3.2 Falcon AU

- (a) Only the Borg-Warner T50D manual five-speed gearbox or the Tremec manual six-speed gearbox may be used.
- (b) It is permitted to modify the rear transmission mounting and cross-member, and the gear change aperture in the floor pan to facilitate the fitment of the T50D manual transmission.

20.3.3 The only gearbox ratios permitted are as specified in the table below:

Gear	Commodore VT, VX, VY & VZ	Falcon AU (Option 1)	Falcon AU (Option 2)	Tremec Option
1 st	3.25:1	3.25:1	3.50:1	2.97:1
2 nd	1.77:1 or 1.99:1	1.99:1	2.14:1	1.78:1
3 rd	1.29:1	1.29:1	1.39:1	1.30:1
4 th	1.00:1	1.00:1	1.00:1	1.00:1
5 th	0.72:1 or 0.83:1	0.78:1 or 0.83:1	0.78:1 or 0.83:1	0.80:1
6 th	N/A	N/A	N/A	0.63:1 or 0.50:1
Reverse	3.15:1	3.39:1	3.39:1	ANY

21. DIFFERENTIAL

21.1 General

- 21.2** The differential action of the rear axle shall be disabled. A “mini spool” may be fitted to the existing differential casing or a full spool may replace the original differential carrier assembly.
- 21.3** It is permitted to fit mechanically identical replacement rear axles or half shaft assemblies.
- 21.4** It is permitted to fit one flexible pipe to carry air to the final drive assembly.
- 21.5** Rear axle bearing retainer plates are free.
- 21.6** It is permitted to add baffles to the rear axle housing for the sole purpose of controlling lubricant surge.
- 21.7** The breathers for the differential may have extensions fitted by way of a length of tubing.
- 21.8** A minimum of 2 steel straps of 6mm thickness shall be fitted to retain driveshaft sections in the event of driveshaft failure and be secured to the floor by at least two(2) bolts of minimum 10mm diameter.
- 21.9** The only final drive ratios permitted are as specified in the table below:

Commodore VN & VP	Falcon EA & EB	Commodore VT, VX, VY & VZ	Falcon AU
3.45:1	3.45:1	3.7:1 or 3.73:1	3.45:1

21.10 Trophy Class

21.10.1 Holden Commodore VT, VX, VY & VZ

- (a) It is permitted to fit a Commodore VT V8 differential housing and gears.
- (b) It is permitted to fit the Harrop “Enduro” differential cover (Harrop part no. 99-ACVR6941-00).

Appendix A

Regulation 8 (Safety Cage)

Diagram 1 (Holden Commodore)

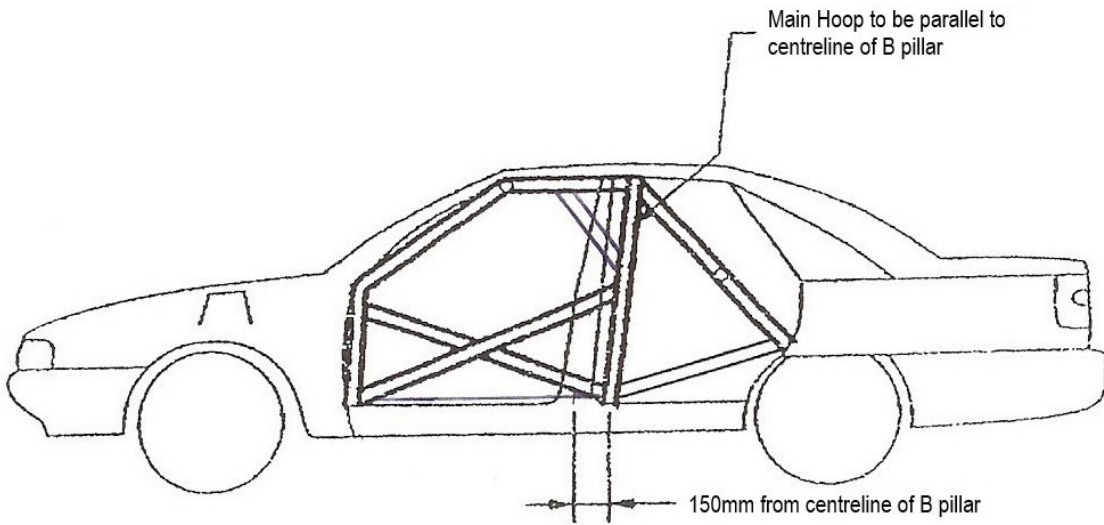

Diagram 1 (Ford Falcon)

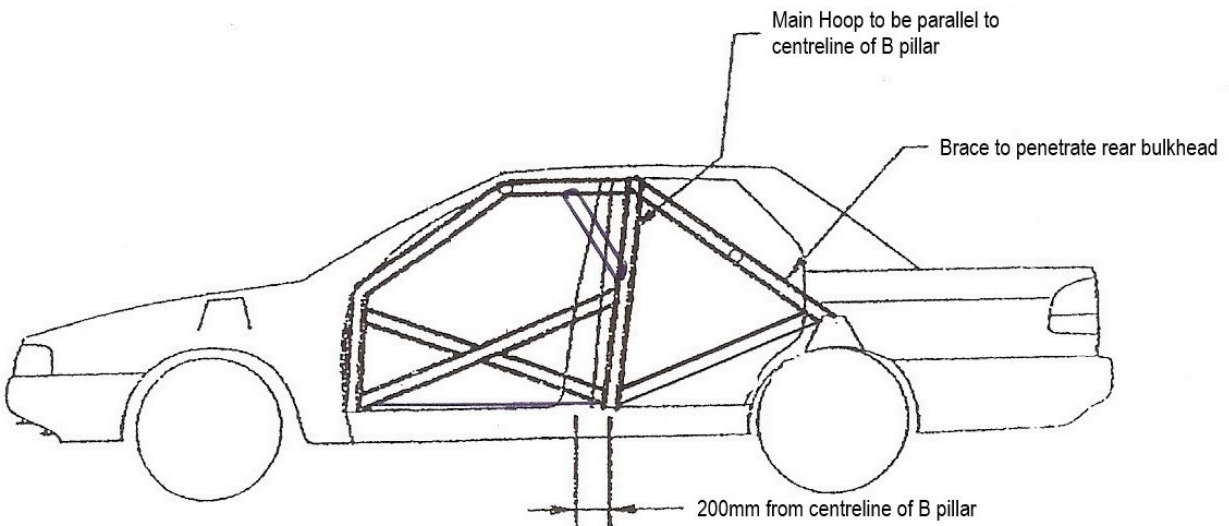

Diagram 2 (Holden Commodore)

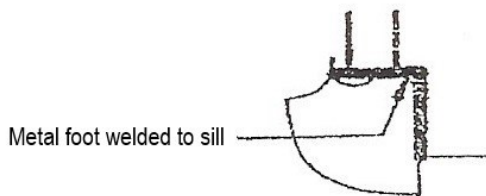

Diagram 2 (Ford Falcon)

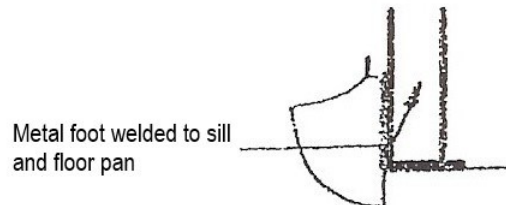

Diagram 3 (Holden Commodore)

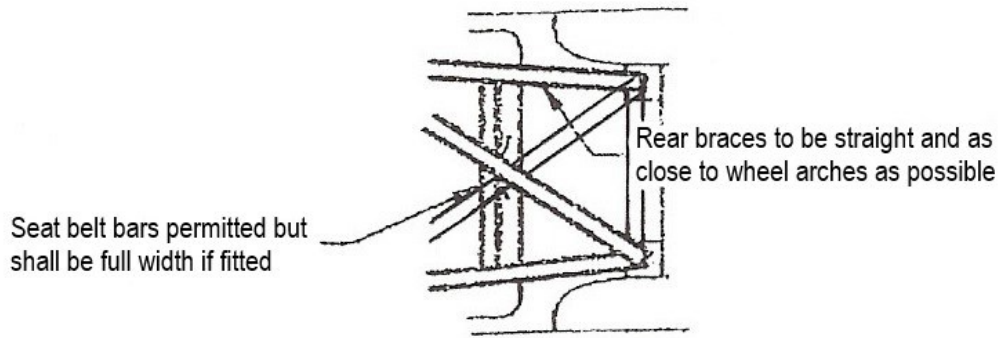

Diagram 3 (Ford Falcon)

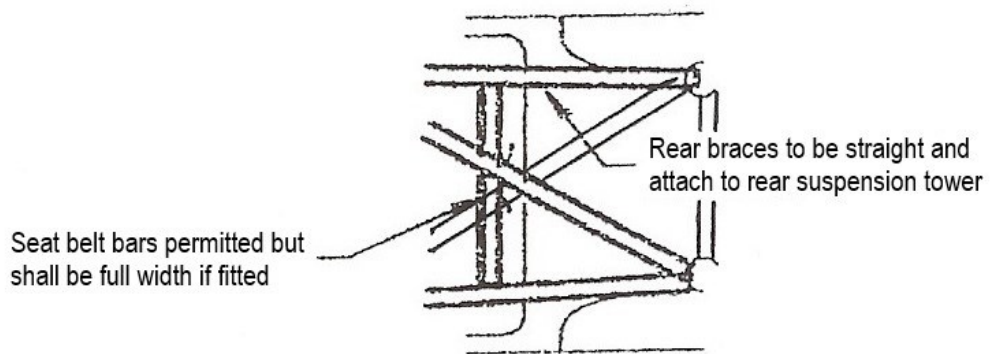

Diagram 4

Screen brace
maximum length 330
mm

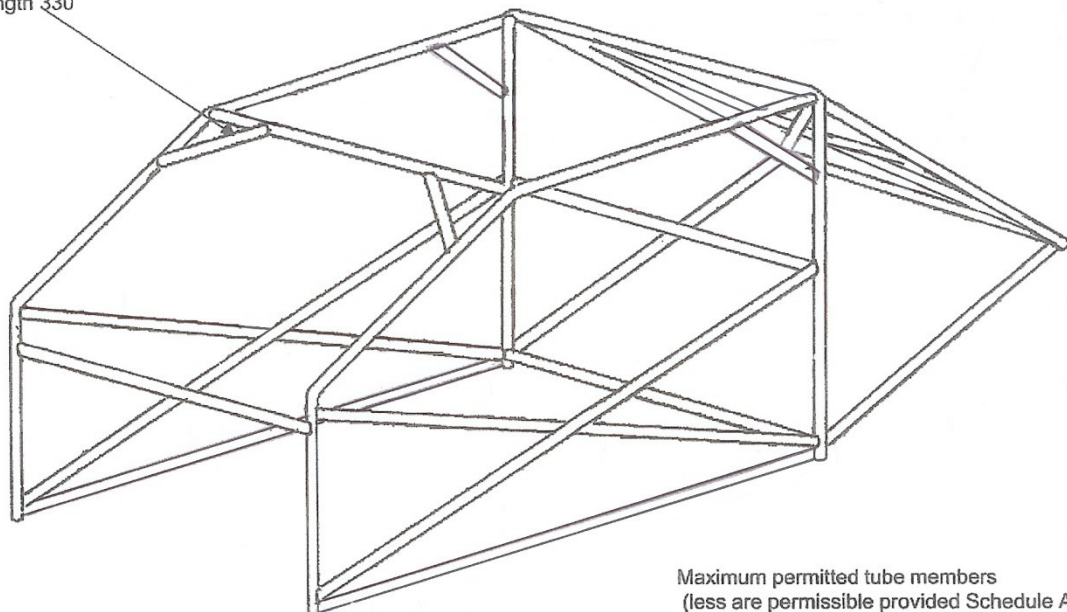

Diagram 5

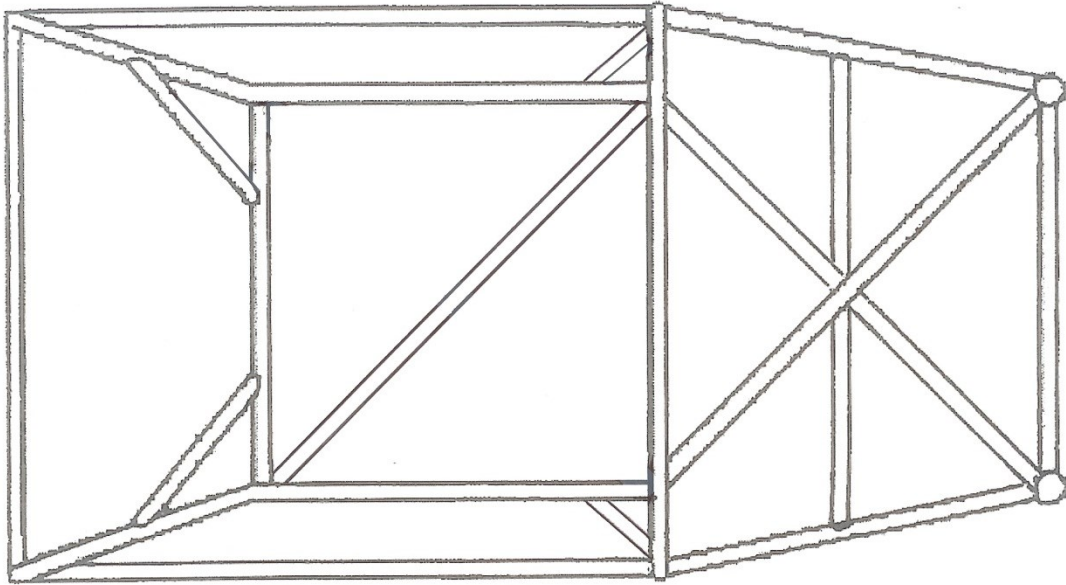

Diagram 6

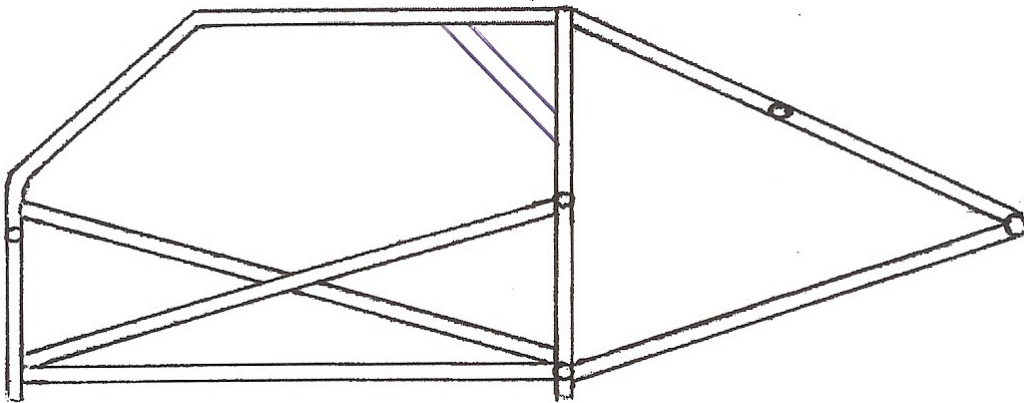
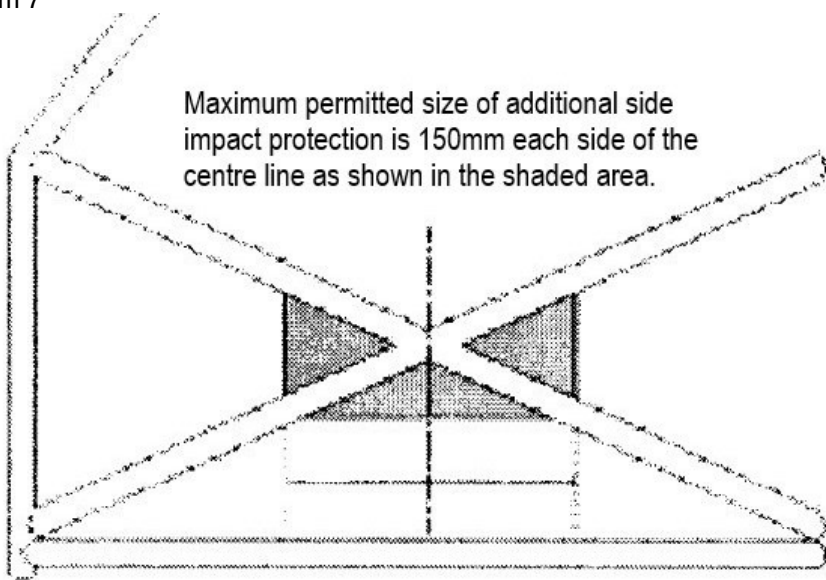

Diagram 7

Maximum permitted size of additional side impact protection is 150mm each side of the centre line as shown in the shaded area.



Appendix B

Regulation 9.2.1(a) (Suspension & Steering - Holden Commodore VN & VP)

Panhard bar reinforcement

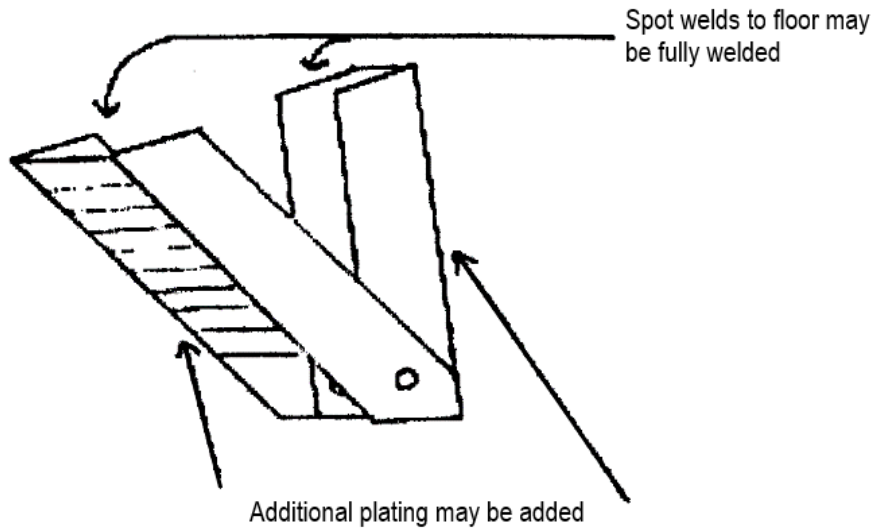

Appendix C

Regulation 9.2.1(b) (Suspension & Steering - Holden Commodore VN & VP)

Front track modification

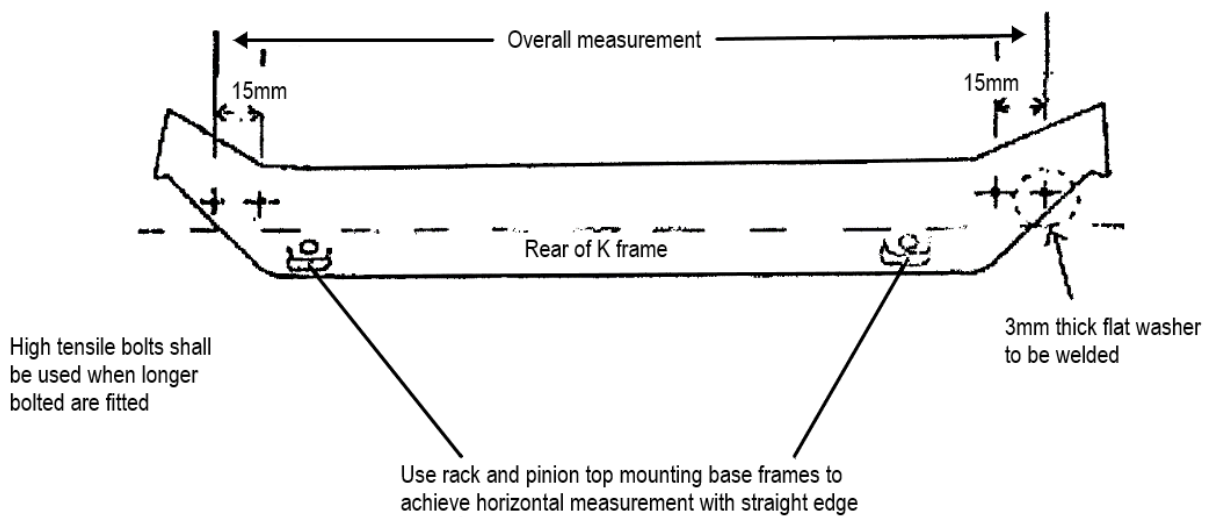

Appendix D

Regulation 9.2.2(a)(iii) (Suspension & Steering - Ford Falcon EA & EB)

Additional idler pulley

ADDITIONAL IDLER PULLEY TO SUPPORT THE FALCON POWER STEERING PUMP DRIVE BELT.

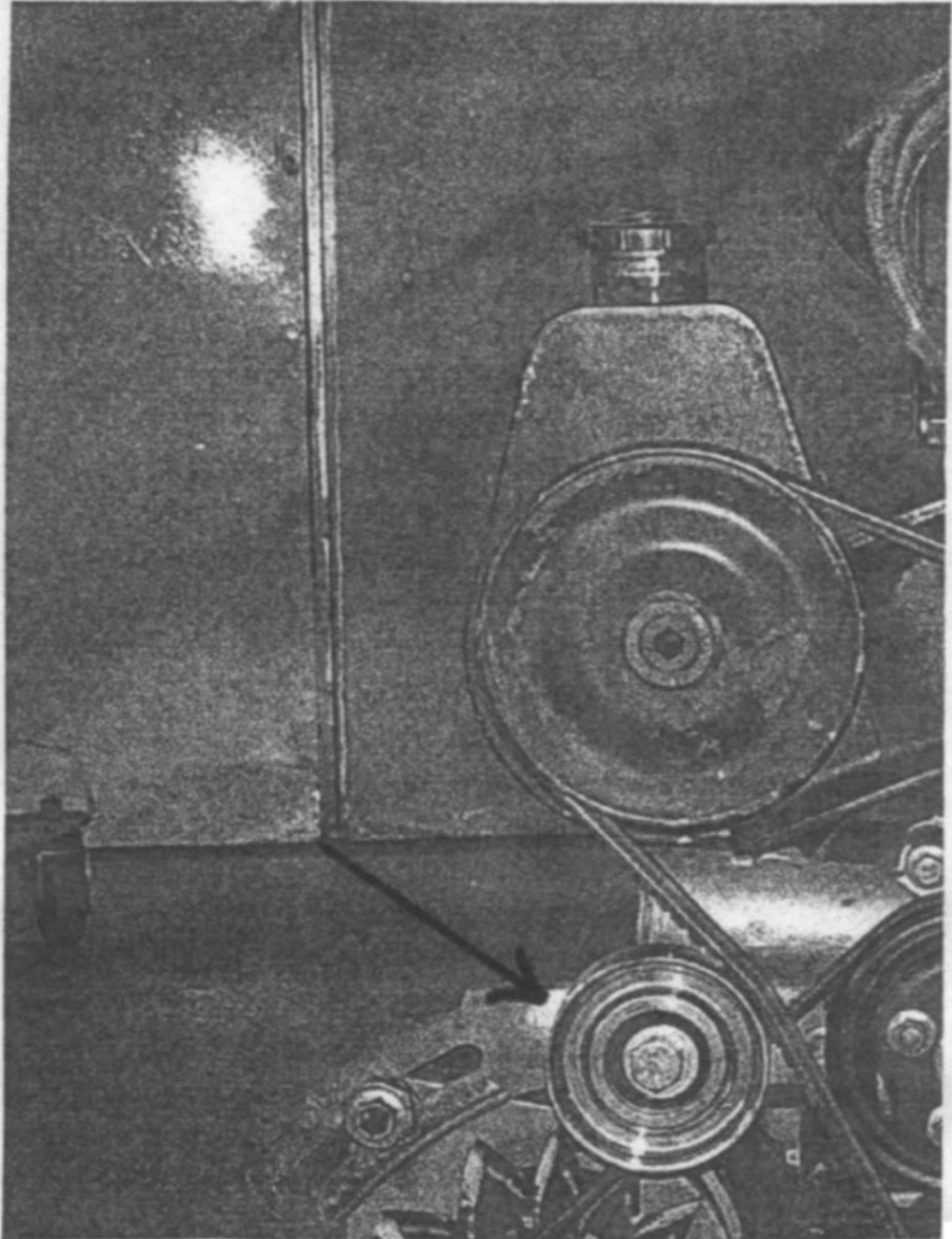

FALCON POWER STEERING PUMP DRIVE BELT IDLER PULLEY MOUNTED DIRECTLY TO THE ALTERNATOR BELT ADJUSTMENT BRACKET

Appendix E

Regulation 9.3.1(b)(i) (Suspension & Steering - Holden Commodore VT, VX, VY & VZ)

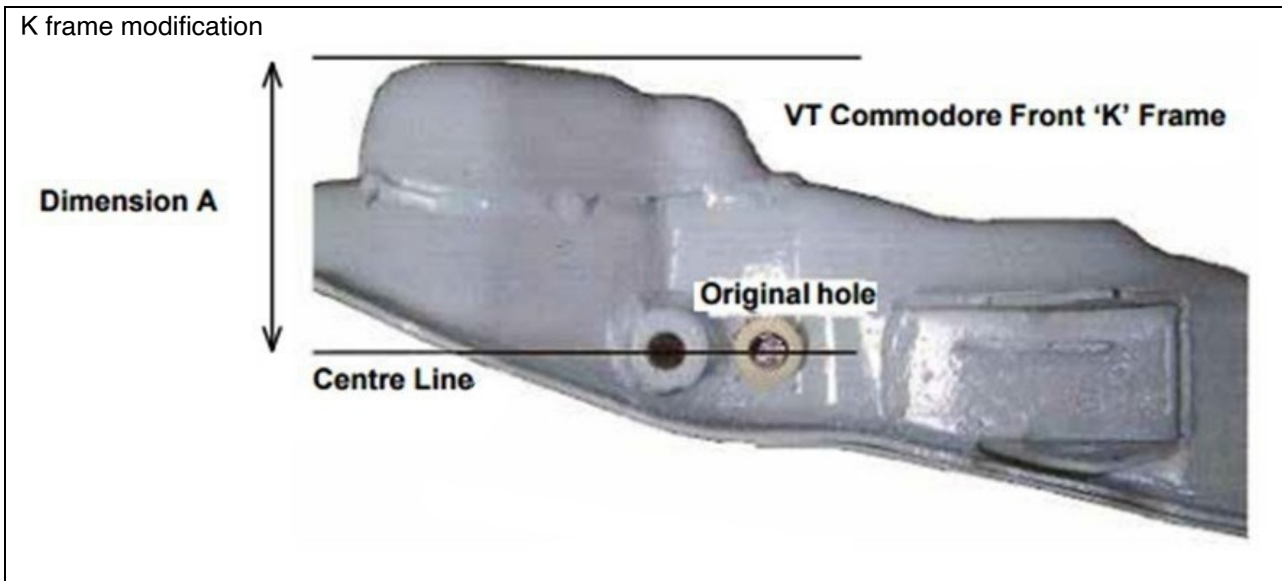

Appendix F

Regulation 9.3.1(b)(v) (Suspension & Steering - Holden Commodore VT, VX, VY & VZ)

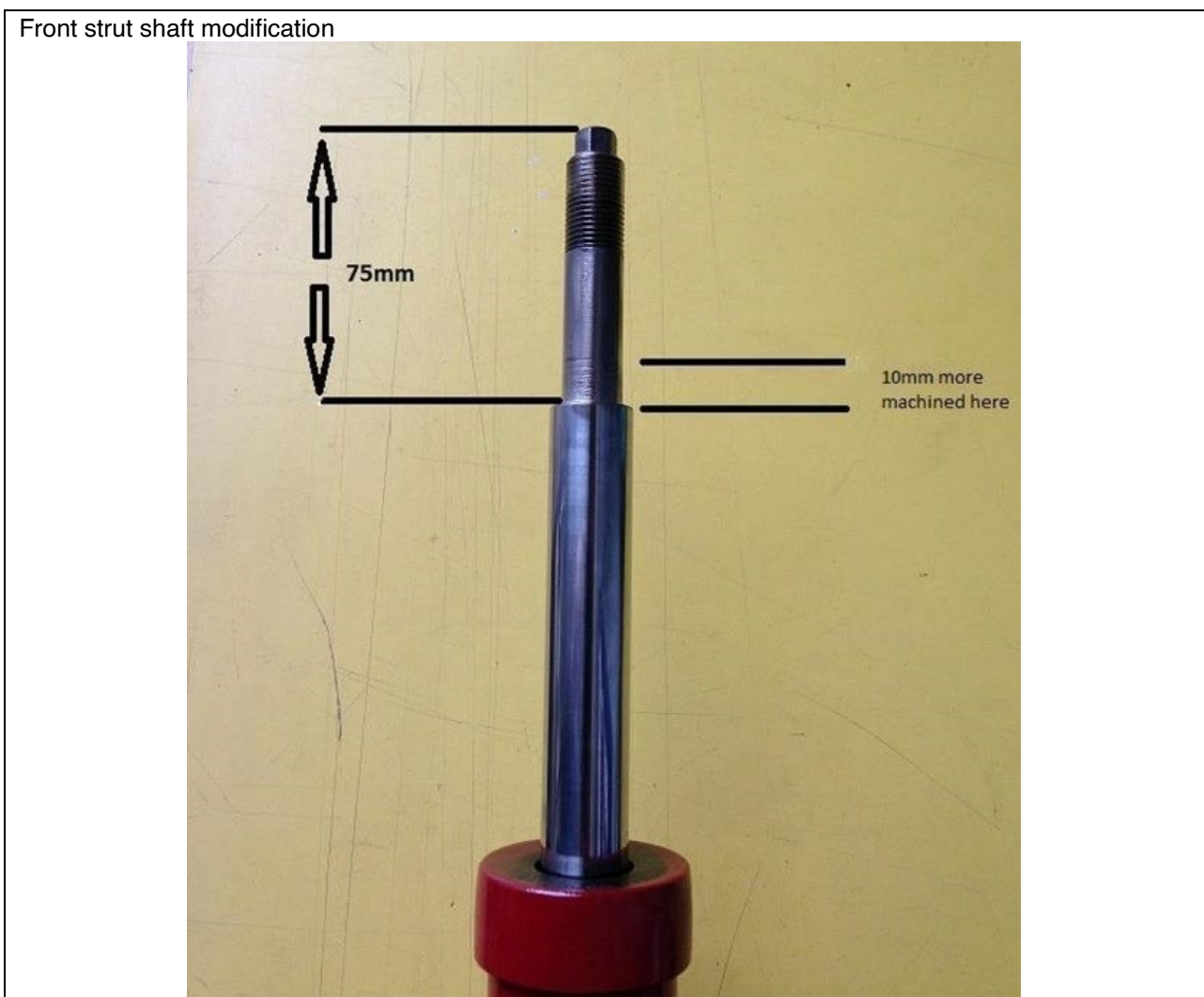

Appendix G

Regulation 9.3.2(c) (Suspension & Steering - Ford Falcon AU)

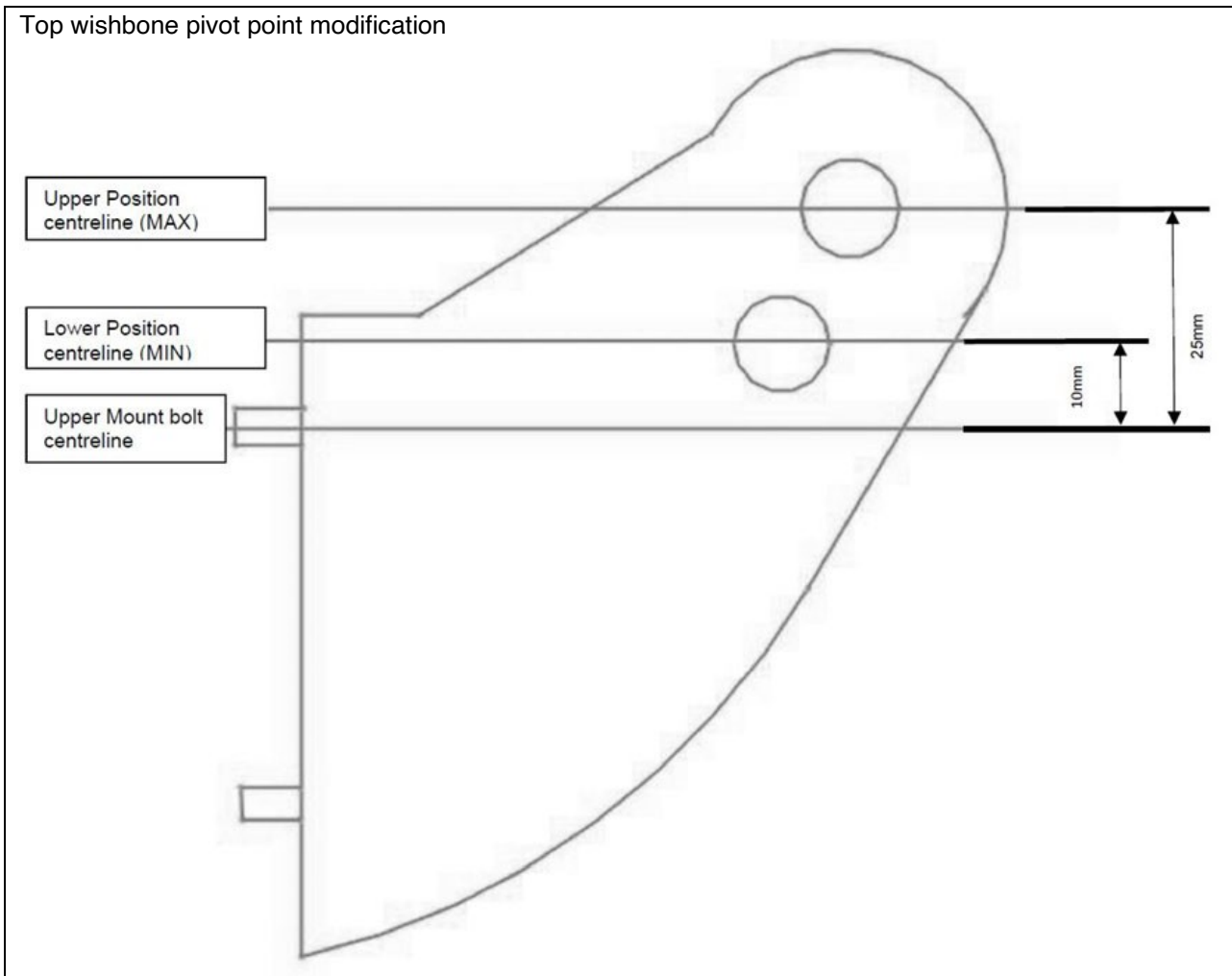

Appendix H

Regulation 10.9.2 (Braking System - Cup Class)

Front brake air intake duct installation - Commodore VN & VP

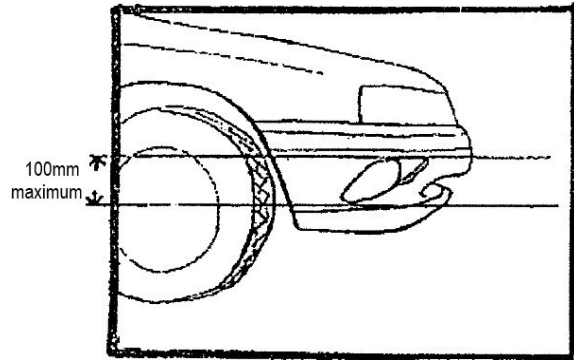
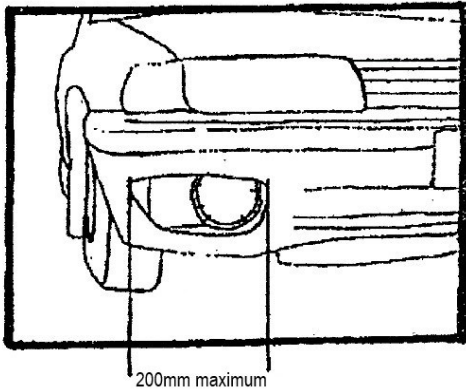

Front brake air intake duct installation - Falcon EA & EB

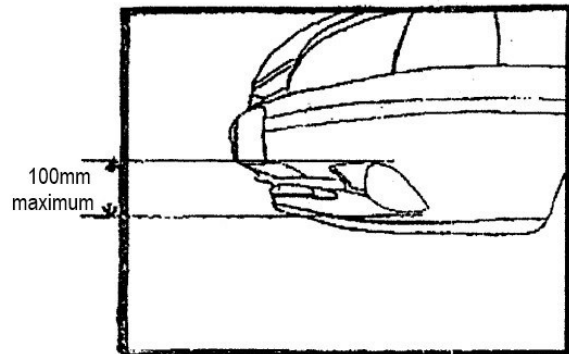
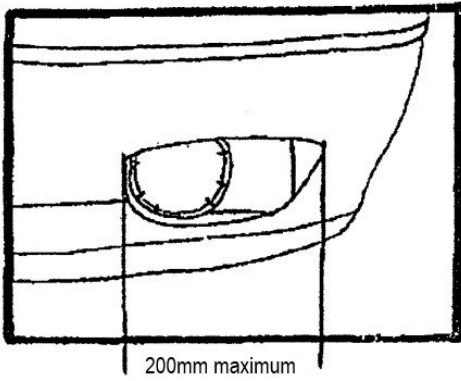

Appendix I

Regulation 16.2.1(g)(iv) (Engine Specifications - Commodore VN & VP)

Regulation 16.3.1(g)(iv) (Engine Specifications - Commodore VT, VX, VY & VZ)

Match porting of the inlet manifold ports

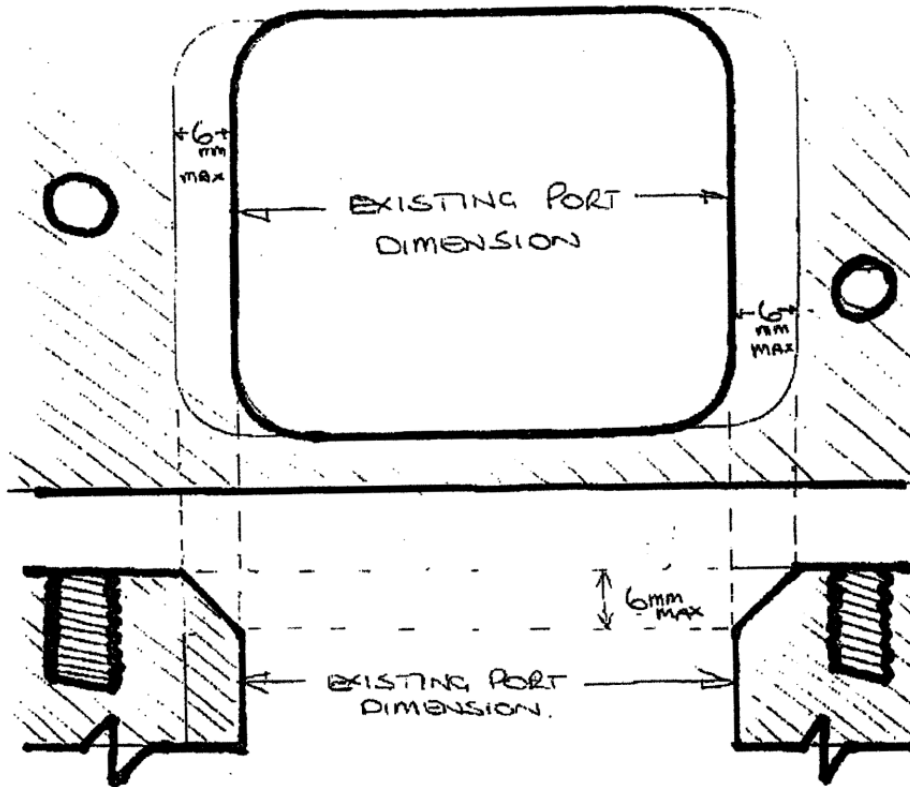

Appendix J

Regulation 16.2.2(f)(iv) (Engine Specifications - Falcon EA & EB)

Regulation 16.3.2(f)(iv) (Engine Specifications - Falcon AU)

Match porting of the inlet manifold ports

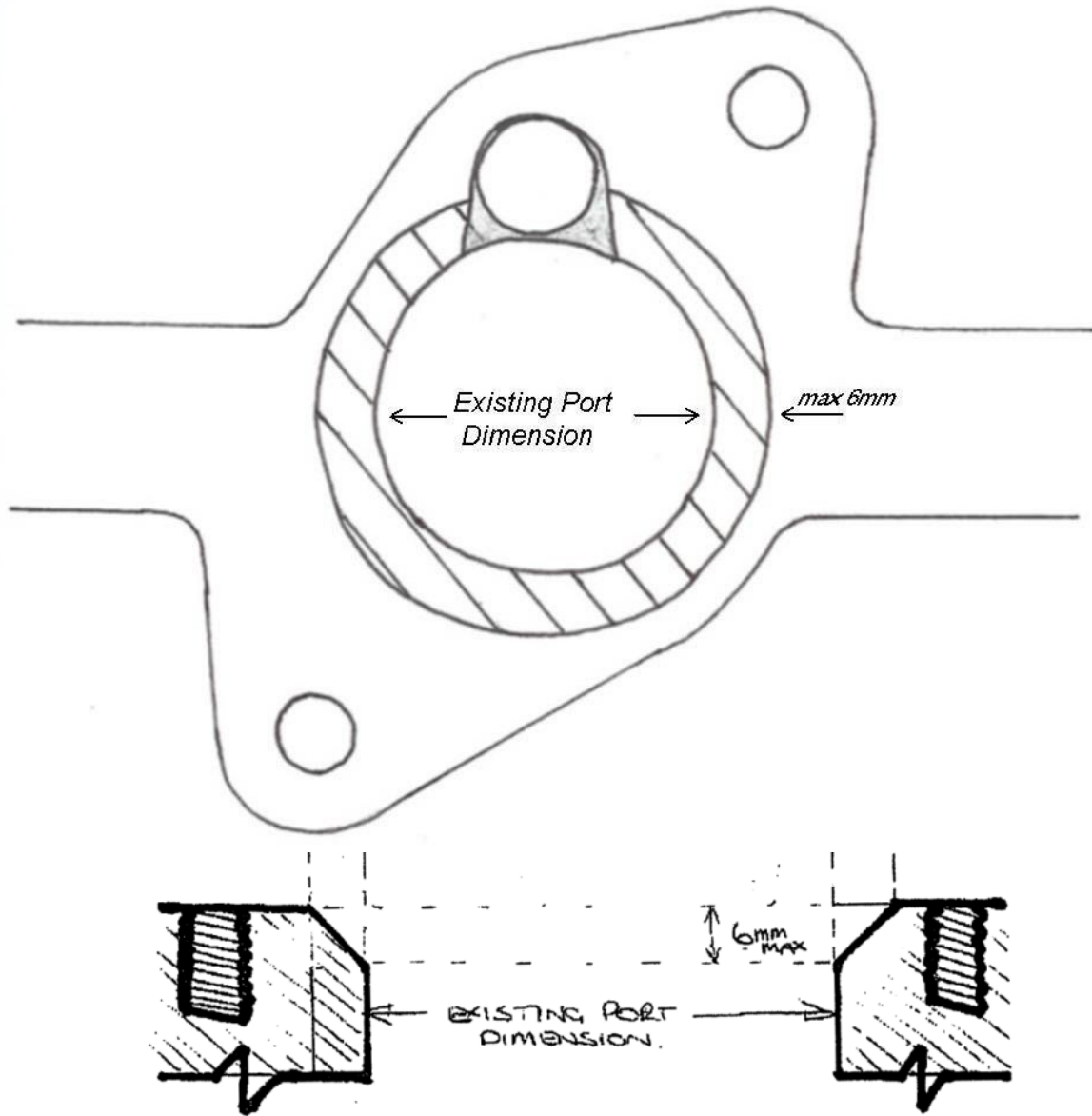

Appendix K

Regulation 18.2.1 (Cooling)

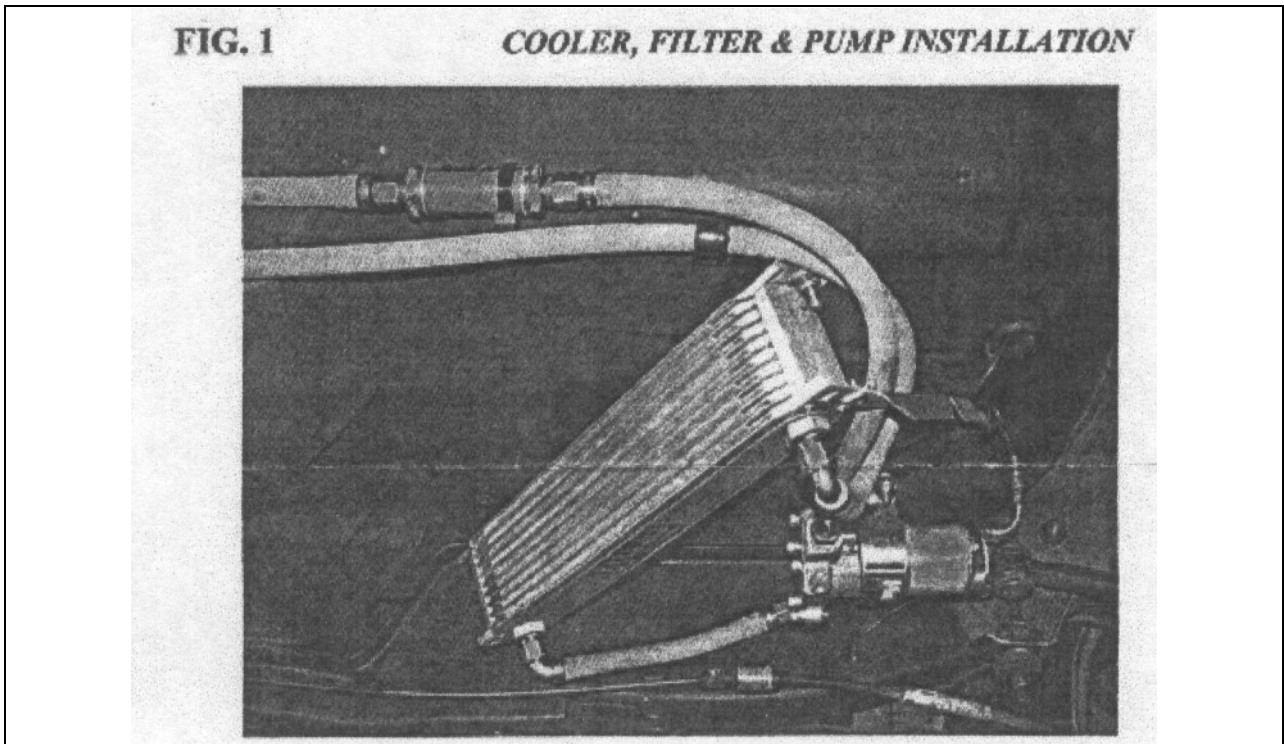

Appendix L

Regulation 18.2.2 (Cooling)

