



ACCREDITED ARTICLES GOVERNING THE 2022-23 Super Mini Challenge Race Series

Preamble

The Mini Racing Drivers Club of NZ Inc. hereby declares the following articles to be those governing a Motor Racing Series for drivers of Super Mini Challenge (SMC) eligible cars.

The Series is held under a MotorSport New Zealand Accredited Permit No: 220410

The Series is organised and held in accordance with the MotorSport NZ National Sporting Code, the Standing Regulations applicable to all Races (Schedule Z) and any Supplementary Regulations applicable to and issued by the Organising / Inviting Club of each Round of the Series.

These articles are at all times to be read in conjunction with:

- The National Sporting Code (NSC) and its appropriate Appendices and Schedules,
- The Technical Regulations - Schedule SMC
- The Event Supplementary Regulations issued by the inviting Clubs.

Note: *All text changes from the previous issue of this Schedule are highlighted such. Text changes for grammatical and/or formatting reasons are not highlighted.*

OFFICIAL RECORD OF AMENDMENTS ISSUED TO THESE ARTICLES

This table records all official Amendments issued during the season relative to these Articles;

Amendment Number	Issue/Effective date	Article reference	Subject / Notes
SMC-22-A001	12 09 2022	7	Round Formats

1. INTERPRETATION:

In these Articles, the definition of terms used within this Schedule shall be referenced from the National Sporting Code, and as detailed below:

“The Series” means the 2022-2023 Super Mini Challenge Series for vehicles complying with Schedule SMC; and

“The Club” means the Mini Racing Drivers Club of N.Z Super Mini Challenge Incorporated, and

“Round Organiser” or **“Inviting Club”** means the MotorSport NZ Member Club organising a Meeting and/or Event which is a round of the Series; and

“National Sporting Code” or **“NSC”** means the National Sporting Code issued by MotorSport NZ from time to time; and

“Round” means each Meeting and / or Event, the results of which qualify for points in the Series; and

“Scratch Grid” means the method of forming cars into a race grid, ranked by each Driver’s fastest recorded lap time in Qualifying Session(s) or any preceding Race held at that Round of the Series, from fastest lap time in the highest grid position to slowest lap time in the lowest grid position; and

“Delayed Class Grid Start” means the method of forming cars into a race grid, grouped into separate grids by Technical Class rules, with a time delay between each successive Class grid being released by the starter.

2. OBJECTIVE:

The Mini Racing Drivers Club of New Zealand Inc. administers the ‘Super Mini Challenge’ motor racing Series for Entrants and Drivers of ‘Classic Minis’ and the newer BMW MINIs compliant with Schedule SMC (refer Part Two of these articles). The Series regulations have evolved on an annual basis since the inception of the ‘Super Mini Challenge’ in 1995, evolving from the North Island ‘Mini 7’ Series. The ‘Mini 7’ class itself has been in existence in New Zealand since 1972 and continues in the North Island today as one of the Classes in the ‘Super Mini Challenge’ Series.

All persons connected with the administration of this Series and with the operation of vehicles competing in the Series are expected to abide by the spirit and intent of these Articles.

3. ELIGIBILITY:

3.1 DRIVER ELIGIBILITY:

3.1.1 All Drivers shall hold a C1 Grade Competition Licence or higher and where the Entrant is other than the Driver, an Entrant’s Licence is required in the name of the Entrant.

Notes:

- 1. Under the provisions of the Trans-Tasman Visa Agreement between Motorsport Australia and MotorSport New Zealand Inc, Australian competitors holding both a Motorsport Australia Circuit Competition Licence and Trans-Tasman Visas may enter any round of the Series.*
- 2. All other overseas competitors shall be bound by the requirements of MotorSport NZ Foreign Participation and shall be eligible for Series points.*

3.1.2 All Drivers and Entrants shall be financial members of the Mini Racing Drivers Club of N.Z Mini Challenge or any MotorSport NZ affiliated Club.

3.2 VEHICLE ELIGIBILITY:

3.2.1 Eligibility shall be for vehicles complying with the specifications as detailed in the Technical Regulations, Schedule SMC. It is the Competitors responsibility to ensure that their car complies with the appropriate technical regulations of the Class entered at all times during competition.

3.2.2 All Competitors / Entrants shall agree to submit their vehicle for eligibility / safety scrutineering inspections as and when required by the appointed Series Scrutineer, and/ or a MotorSport NZ licensed Technical Officer. Any costs incurred during disassembly of components shall be met and accepted by the Competitor/ Entrant.

3.2.3 Official Series Seals may be applied by the Series Scrutineer, and / or a MotorSport NZ licensed Technical Officer, to components and/ or assemblies of components in compliance with Appendix Two, Schedule A, Article 3.7. All seals shall be clearly detailed in the vehicles MotorSport NZ logbook.

3.2.4 CLASSES: There are four distinct classes as follows;

(1) **Class 1: Mini Seven;** being cars in compliance with Schedule SMC, Part B, Section One, Technical Regulations applicable to Mini Seven Class.

(2) **Class 2: Mini Miglia NZ;** being cars in compliance with Schedule SMC, Part B, Section Two, Technical Regulations applicable to Mini Miglia NZ Class.

(3) **Class 3: Super Mini;** being cars in compliance with Schedule SMC, Part B, Section Three, Technical Regulations applicable to Super Mini Class.

(4) **Class 4: Mini Open Class;** being cars in compliance with Schedule SMC, Part B, Section Four, Technical Regulations applicable to Open Mini Class.

3.3 All Competitors shall ensure that their competing vehicle has the specified spaces reserved for Series and Sponsor decals (supplied by the Club) at all Rounds of the Series, as detailed in Appendix One of these Articles.

(1) The primary reserved position is as stated first, with a secondary option given in brackets (where an option is allowed).

(2) Competition number sets shall comply with the requirements of Schedule A, Article 6.2, and the Driver's surname shall appear on both of the vehicle's rear side windows.

Note: *Competition numbers sets, and Driver's surname decals shall be provided and applied by the Competitor.*

3.4 The Club reserves the right to amalgamate with or compete in conjunction with any other race series, class or Club at any Round of the Series without in any way affecting its powers to award any title. Any such invitation shall be decided by the Committee.

4. SERIES PERSONNEL:

4.1 At each Round of the Series the following personnel or their approved assistant/s shall have the responsibilities and authorities as set out:

4.1.1 Series Coordinator: Phil Deane
Home Phone No: 04 526 2057
Mobile Phone No: 021 494 407
Email: phil.classicminis@gmail.com

Who shall have the duties and authority of a Series Coordinator as set out in the National Sporting Code and who is responsible for and authorised on the Club's behalf to:

- (a) Deal with all administrative matters pertaining to the Series, and
- (b) Record and publish all Series points schedules, and
- (c) Liaise with Inviting Club/s on all matters pertaining to these Articles, and
- (d) Ensure correct placement of decals on vehicles contesting the Series, and
- (e) Provide the Inviting Club/s with grid starting positions where these differ from those detailed in Appendix Four Schedule Z, Article 6.1, and

Who may have deputies and assistants to whom they may delegate any of their responsibilities and authorities by way of notice posted on the official notice board at each Round.

4.1.2 Series Secretary: Kevin Sweeney
Phone Home: 07 8466607
Mobile Phone No: 027 242 5398
Email: Kevin.margaret@xtra.co.nz

Who is responsible for and authorised on the Club's behalf to manage all correspondence and administrative matters of the Series.

Who may have deputies and assistants to whom they may delegate any of their responsibilities and authorities by way of notice posted on the official notice board at each Round.

4.1.3 Series Scrutineer: Ken Douglas
Mobile Phone No: 027 530 2614
Email: automotion-motorsport@xtra.co.nz

Who shall have the authority of a Series Scrutineer set out in the National Sporting Code and who is responsible for and authorised on The Register's behalf to:

- (a) Deal with all technical matters pertaining to the Series, and
- (b) Affix official seals, as and when deemed appropriate, and
- (c) Inspect any competing vehicle within the Series in order to ascertain compliance with the technical regulations, and

- (d) Assist competitors with technical inquiries relative to the technical regulations applicable to their vehicle, and
- (e) To report, to the Series Coordinator, any instances where a breach of the technical regulations has been proven.

Who may have deputies and assistants to whom they may delegate any of their responsibilities and authorities by way of notice posted on the official notice board at each Round.

4.1.4 Super Mini Challenge

President: Evan Thompson
Phone Home: 09 8179506
Mobile Phone No: 021 935 643
Email: evan@otbury.co.nz

4.1.5 Super Mini Challenge

Treasurer: Chris Thompson
Mobile Phone No: 021 240 7741
Email: c.r.thompson13@gmail.com

- 4.2 All correspondence shall be addressed to the Series Secretary who is authorised by the Club to carry out all the necessary administrative duties for the Series. Correspondence is to be addressed to:

The Mini Racing Drivers Club Secretary,
59 Tupelo St
Pukete
Hamilton 3200

5. SERIES ENTRY:

- 5.1 Entry into the Series should be made with the Club Secretary by completing the Series Entry form (see Appendix Two).
- 5.1.1 The Series entry fee will be \$75.00. Any entry will not be deemed valid until payment is received.
- 5.1.2 The Series reserves the right to accept or decline entries into the series as per NSC 21.
- 5.2 By entering the Series all Competitors/Entrants:
- (1) Are deemed to be in acceptance of these Series Articles as they are presented, and
 - (2) Agree to comply with these Articles and those of the National Sporting Code, and
 - (3) Shall be at all times responsible for the presentation of their competing vehicle with respect to safety requirements under Schedule A, and eligibility requirements under Schedule SMC.
- 5.3 Entry to each Round of the Series (which is separate to the Series Entry) should be made as directed in the Meeting Supplementary Regulations.

6. SERIES STRUCTURE:

6.1 The Series shall comprise of the following Rounds:

Round	Date	Venue	Inviting Club
1	22-23 October 2022	Manfeild: Circuit Chris Amon	Manawatu Car Club
2	12-13 November 2022	Manfeild: Circuit Chris Amon	MG Classic Racing Register Inc
3	10-11 December 2022	Pukekohe Park Raceway	Speedworks Motorsport Club
4	7-8 January 2023	Taupo International Motorsport Park	Historic Racing Club
5	25-26 February 2023	Pukekohe Park Raceway	Historic Racing Club
6	18-19 March 2023	Hampton Downs Motorsport Park	Historic Racing Club
7	15-16 April 2023	Taupo International Motorsport Park	Historic Racing Club

6.1.1 The Series reserves the right to either cancel or amend any Rounds of the Series due to force majeure without affecting in any way its power to award any title.

7. ROUND FORMAT

7.1 **Test Session(s):** may be available to Drivers on the Friday prior to any Round of the Series and shall be subject to availability and track hire charges as set by the Inviting Club(s).

7.2 Super Mini Challenge will run with the Pre-65 Accredited Race Series in one(1) combined grid.

7.3 **Qualifying Session(s):** shall be a minimum of fifteen(15) minutes duration.

7.4 **Race format:** There are planned to be three races at each Round. A fourth race may be run at some Rounds where program times permit.

7.5 **Races distances:**

Round	Venue	Race 1	Race 2	Race 3
1	Manfeild: Circuit Chris Amon	8 Laps	8 Laps	8 Laps
2	Manfeild: Circuit Chris Amon	8 Laps	8 Laps	8 Laps
3	Pukekohe Park Raceway	8 Laps	8 Laps	8 Laps
4	Taupo International Motorsport Park	6 Laps	6 Laps	6 Laps
5	Pukekohe Park Raceway	8 Laps	8 Laps	8 Laps
6	Hampton Downs Motorsport Park	8 Laps	8 Laps	8 Laps
7	Taupo International Motorsport Park	6 Laps	6 Laps	6 Laps

7.6 **Races (Round 1 through to Round 6):** shall be run to the following race structures:

- (a) **Race One:** Shall be a 'Scratch Grid Start'. The entire field of cars shall form a single grid, determined by qualifying times from Qualifying Session(s), fastest driver to the front.
- (b) **Race Two:** Shall be a full Handicap Race Grid Start. Each SMC class will start as a delayed grid with each SMC grid positioned within the Pre-65 handicap; determined by the fastest driver within each SMC Class.
- (c) **Race Three:** Shall be a "Handicap Race Grid Start", as per Schedule Z Article 8.4. Handicap split times shall be calculated by the Series Coordinator, in consultation with the meeting officials, based on each driver's fastest lap time from Qualifying Session(s), Race One and Race Two.

7.7 Races (Round 7): shall also include the invited Mini 7 Association Series and shall run to the following formats:

(a) Class 1: Each Race shall be a 'Scratch Grid Start', determined by fastest lap time of the meeting to date, fastest driver to the front.

(b) Class 2, 3 and 4:

(i) Race One: Shall be a 'Scratch Grid Start'. The entire field of cars shall form a single grid, determined by qualifying times from Qualifying Session(s), fastest driver to the front.

(ii) Race Two: Shall be a full Handicap Race Grid Start. Each SMC class will start as a delayed grid with each SMC grid positioned within the Pre-65 handicap; determined by the fastest driver within each SMC Class.

(iii) Race Three: Shall be a "Handicap Race Grid Start", as per Schedule Z Article 8.4. Handicap split times shall be calculated by the Series Coordinator, in consultation with the meeting officials, based on each driver's fastest lap time from Qualifying Session(s), Race One and Race Two.

7.7.1 Where event scheduling allows Class 1 may be a separate race.

7.7.2 Where event scheduling doesn't allow a separate race, Class 1 shall be its own group within the grid and shall start either in front or behind the other classes (as determined by the Series Coordinator), with sufficient delay to ensure minimum interference with the other classes.

Note: *The Series Coordinator reserves the right to combine classes in each Race where any Class is represented by three(3) or less cars. Cars forming the grid of a slower Class shall be combined into the grid of cars in the next fastest Class. This shall affect only the on-track positioning of cars. The award of Class points from the race results shall remain unaffected.*

7.8 Any driver that does not participate in Qualifying may only start any or all races at the absolute discretion of the Clerk of the Course. The Series Coordinator will request that the Clerk of the Course allows any approved cars to start as last car/s in their respective class. Where more than one vehicle per class is involved the Series Coordinator will request that the driver with the most points from the Class Points Table be allowed to start highest of those involved, with others then following in descending points order.

7.9 At all Rounds, the Series Coordinator in conjunction with the Clerk of the Course and/or the Stewards of the Meeting, reserves the right to shorten and/or cancel any practice/qualifying sessions and/or Races in the case of Force Majeure.

8. PARC FERME:

8.1 Upon directive from the Series Scrutineer or their appointed assistant, competitors may be required to drive their competing vehicle directly (and without any team personnel / crew intervention) from the track to the designated Parc Fermé, the location of which will be notified on the official notice board of the Meeting.

Note: *Drivers should ensure that they and all their team personnel are familiar with the Parc Fermé regulations and limitations as detailed in the National Sporting Code Article 60.*

8.2 The Series Scrutineer may authorise the entry of team personnel for the purposes of vehicle eligibility inspections.

9. PENALTIES, PROTESTS AND APPEALS:

9.1 Penalties shall be applied in accordance with the prescribed articles of NSC Part VIII - Penalties.

9.2 Any protest or appeal should be lodged in accordance with the NSC and the Competitor shall (as a matter of courtesy) advise the Series Coordinator and the Competitor Relations Officer (where appointed for the Meeting).

9.3 Competitors/ Entrants have the right to lodge a Protest/s in accordance with NSC Part IX – Protests.

9.4 Competitors/ Entrants have the right to lodge an Appeal in accordance with NSC Part XI – Appeals.

10. POINTS:

10.1 Points will be allocated to Drivers based on their Class finishing positions in each Qualifying session and each Race, at all Rounds of the Series.

10.1.1 Points will be allocated to all competitors in each event.

Note: Competitors who are not current members of The Club are not eligible for Series awards and prizes. Should a non-Club member win a trophy position, the trophy will not be awarded for that season.

10.2 The Series points will be allocated for Class placing in each of the four(4) Classes, awarded as follows:

1 st	20	7 th	6
2 nd	15	8 th	5
3 rd	12	9 th	4
4 th	10	10 th	3
5 th	8	11 th and	2
6 th	7	Lower	

10.3 Additional Bonus Points are awarded as follows:

(1) Fastest lap in each Class in each Race = 1 Point

(2) Each Competitor shall receive double Points for their Race 1 Class placing result at each Round held furthest away from their hometown.

11. AWARDS:

11.1 The presentation of Series Awards shall be made at the conclusion of the Series, at a time and place and in a manner as specified by the Club.

11.2 The **OVERALL SERIES WINNER** shall be the Driver with the highest total of all points accumulated during the Series.

11.3 The Series and Class winner/s shall receive the following award/s:

- (a) **Series:**
- Overall Series Champion
 - 2nd overall in the Series
 - 3rd overall in the Series
- (b) **Classes 1 - 4:**
- 1st overall in the Class
 - 2nd overall in the Class
 - 3rd overall in the Class

12. IN-CAR CAMERAS

- 12.1** All in-car camera installations shall be fitted in accordance with Appendix Two, Schedule A, Part One, Article 6.4 and shall be subject to inspection and approval by the Series Scrutineer and/or Chief Scrutineer of the Meeting.
- 12.2** In-car camera footage must be made available to the Clerk of the Course and/or Steward(s) upon request.

13. TIMEKEEPING

- 13.1** The Round Organiser, the Inviting Club, the host circuit or the Series Coordinator shall provide timing equipment that will be deemed to be the official timing equipment for the meeting.
- 13.2** All competitors shall ensure that timing equipment is looked after with all due care and attention whilst in their possession and that all equipment is returned as and when requested.
- 13.3** Official timing of Qualifying Session(s) and Races shall be by electronic timing system, when available at Series Rounds. Such electronic timing shall use MyLaps circuit compatible timing transponders.
- 13.3.1** For all vehicles excepting BMW MINIs, the timing transponder shall be mounted securely onto the vehicle, in accordance with manufacturer's installation instructions. No part of the timing transponder unit, major or minor, shall be forward of a nominal vertical datum plane at 90 degrees to the front subframe top plane. The datum plane shall be 200mm forward of the intersection of the front subframe top plane and the suspension tower, as per the following diagram. The vertical centre-line axis of the timing transponder unit must not face forward of true plumb (vertical), independent of the position of mounting. BMW MINIs shall comply with the requirements of Schedule A, Part One, Article 6.3 (1).

Note: *Only one (1) transponder unit is to be used. Three (3) transponder units are shown to indicate freedom of mounting position provided this is behind the datum plane.*

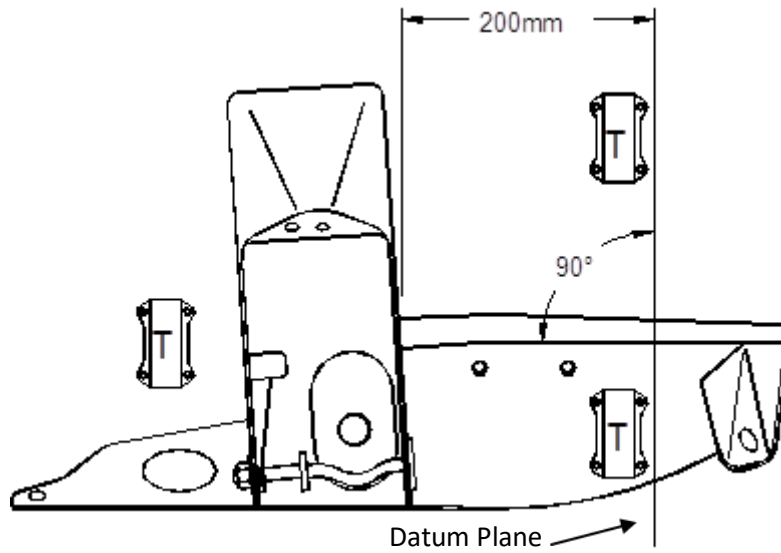

These Accredited Series Articles are issued for 2022-2023 Super Mini Challenge Race Series by the Administration.

A handwritten signature in black ink, appearing to be 'Raewyn Burke'.

Raewyn Burke
Sporting Manager
MotorSport New Zealand
29 August 2022

**APPENDIX 1
DECALS**

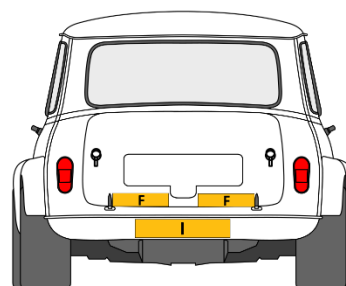
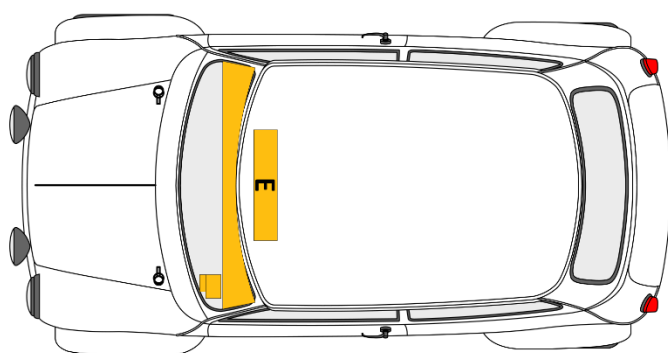
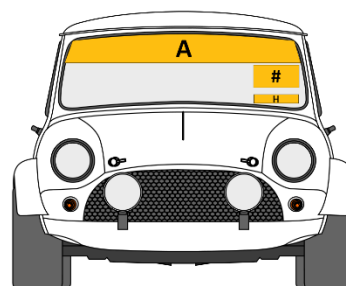
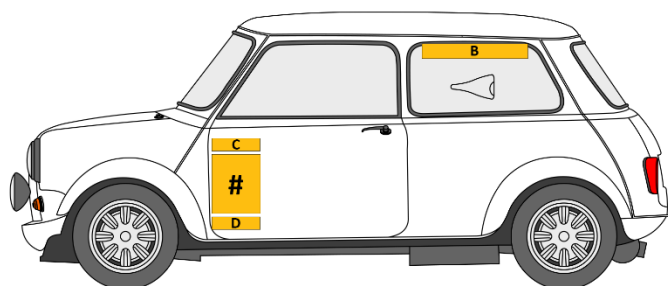

	Location	Branding Decals/ Badges
A	Top of windscreen	Series sponsor banner, being approx 100mm deep, with Class coloured segments of approx 100mm x 120mm.
B	Top of side rear window on both sides of vehicle	Class coloured strip, being same colour as windscreen segments, approx 100mm deep.
C	Above door numbers on both sides of vehicle	Sponsor decal, being approx 180mm x 60mm
D	Near the door numbers on both sides of vehicle	MotorSport New Zealand Accredited Series sticker
E	Roof panel (centre of bonnet)	Reserved for future Sponsor decal (TBA)
F	Rear bumper (lower half of boot lid)	Two Sponsor decals, being approx 120mm long
G	Race overalls	Sponsor badge, not lower than 200mm from top of the overall
H	Bottom edge of windscreen on the passenger side below the car number & leading edge of bonnet	White ' www.miniracing.co.nz ' profile cut lettering decal on windscreen, or; Black or White for contrast on bonnet, approx 600mm x 40mm
I	Centre of rear bumper (centre of rear valence, visible below bumper)	Black or White ' www.miniracing.co.nz ' profile cut lettering decal, for contrast, approx 600mm x 40mm

Appendix 2

Mini Racing Drivers Club INC
Super Mini Challenge Accredited Race Series
Entry Form 2022-2023

Competition Number
<i>For Race Secretary's Use Only</i>

NOTE: MRDC acceptance of this entry is required before the Entrant can place an entry to compete in any of the SMC Accredited Series Rounds. This entry fee is \$75.00.

PLEASE RECORD THIS SERIES ENTRY FOR:

Driver / Entrant Details:			
Driver's Name		First Time Driver (3 or fewer events) <i>(please tick)</i> <input type="checkbox"/> First Time Competitor at Venue <i>(please tick)</i> <input type="checkbox"/> Foreign Participant on Non-MSNZ Licence <i>(please tick)</i> <input type="checkbox"/>	
Physical Address			
Postal Address for Entry Details			
Email Address			
Telephone - Home	Telephone - Business	Telephone - Mobile	
Competition Licence No:		Expiry Date / /	
Licence Grade: (please tick)		<input type="checkbox"/> INT C Grade	<input type="checkbox"/> C1 Grade <input type="checkbox"/> C2 Grade
Financial Member of the following MotorSport NZ Member Club: (Name of Club)			Club Membership Exp Date: / /
Required for statistical purposes Female / Male / Other			Date of Birth:
Age Group (please circle appropriate): 12-16 16-18 19-25 26-35 36-60 61 plus		 / /
Next of Kin	Name:	Relationship:	
	Contact Telephone Number:		
Entrant: <i>(to be completed in all cases if Entrant is other than the driver. Licence must be purchased from MotorSport NZ Inc prior to the event in question and presented at documentation)</i>			
Entrant's Name			
Postal Address			
Email Address			
Telephone - Home	Telephone - Business	Telephone - Mobile	
Fax Number	Entrants Licence Number	Licence Expiry Date / /	
Vehicle Details			
Vehicle Make		Vehicle Model	
Colour		Permanent Race No	
Capacity in cc:	Log Book No: <i>(All vehicles)</i>	Certificate of Description <i>(Schedule K or T&C where applicable)</i>	
Year of Vehicle Manufacture:		Note: Actual year of completion of manufacture for this particular vehicle	
SMC Class for 2021-22 season:			
Mini 7		Super	
Miglia		Open	

1. Indemnity:

I have received the Supplementary Regulations and all other regulations or Articles as determined in the Appendices and Schedules of the current New Zealand Motorsport Manual for the event I am entering and agree to be bound by them and by the National Sporting Code of MotorSport New Zealand Inc.

In consideration of the acceptance of this entry and of my being permitted to take part in the Meeting or Events detailed, I agree not to pursue claims against and (severally) to hold harmless, indemnify and keep indemnified MotorSport New Zealand Inc, its members, associated or affiliated clubs and entities, race and/or event organisers and promoters, the inviting club and entity (or entities), race circuit owners, providers and operators, owners and tenants of private property (including land, buildings and/or fixtures, fittings and chattels) traversed, or proximate to events, officials, fellow competitors, and the directors, officers, servants, representatives and agents of those entities (all together "the Indemnified Parties") in relation to all losses, actions, expenses, costs, liabilities, claims and demands in respect of death, injury, loss or damage to persons or property of myself, and/or my team (including drivers, co-drivers, passengers, management and/or mechanics) whatsoever, caused or arising out of or in connection with this entry or taking part in the events to which this entry relates, notwithstanding that such death, injury, loss or damage may have been contributed to or caused by the negligence of any of the Indemnified Parties and/or by any other person. This provision confers a benefit on, and is intended to be enforceable by, each of the Indemnified Parties (in accordance with the Contracts (Privity) Act 1982).

2. Ability to Control a Vehicle Declaration by Driver:

I declare that should I at the time of any event this entry form relates to be suffering from any disability of any kind whether permanent or temporary which is likely to detrimentally affect my control of my automobile or my fitness to drive, I will not participate.

3. Vehicle Conformance with Schedule A/AA Declaration by Driver:

I declare the vehicle detailed on this entry form complies with the vehicle safety items set out below (as applicable) and will be presented on request to an appointed Scrutineer or Technical Officer complying at all times with the safety and eligibility requirements detailed in the National Sporting Code and its Appendices and Schedules.

Critical Safety	Non-Critical Safety		Non Safety
<ul style="list-style-type: none"> • Helmet • Head & Neck Restraint • Protective Clothing • Safety Harness • Window Net(s) • Roll Bar / Safety Cage • Seat(s) and Mounts • Fire Extinguisher • Wheels and Tyres • Brake System • Steering & Suspension Systems • Fuel Tank(s) / Fillers / Lines 	<ul style="list-style-type: none"> • Engine & Transmission Mounts • Flexible Fluid Lines & Hoses • Throttle Return (Failsafe) • Engine Starter Operation • Reverse Gear Operation • Exhaust System • Oil Catch Tank(s) • Electrical Wiring • Ignition / Circuit Breaker • Battery • Lighting Systems • Brake Lights 	<ul style="list-style-type: none"> • Rear Lights / Rain Lights • Bodyshell / Chassis Condition • Exterior Appearance • Panels / Covers • Doors • Windows • Wipers & Demisting • Rear Vision Mirrors • Aerofoils & Spoilers • Cockpit Construction / Fittings • Bulkheads • Tow Eyes 	<ul style="list-style-type: none"> • Ballast (Security) • Competition Numbers • Registration & WOF Labels • LVV / MSNZ Authority Card • LVV Plate • Optional Equipment

I acknowledge that where any breach of the Safety Schedule is found during a Safety Audit I will be subject to penalties under the National Sporting Code and my signature below indicates my acceptance of this undertaking.

4. Consent:

I consent to the details contained on this form being held by MotorSport New Zealand Inc and/or the Inviting Clubs for the purpose of the promotion and benefit of the Race Meetings or Events concerned, and Motorsport in general. I acknowledge my right to access and correction of this information. This consent is given in accordance with the Privacy Act 1993.

I also authorise the medical providers of the event to disclose medical information relevant to illness or injury sustained during the above mentioned event to MotorSport NZ and its officials.

Signature of Driver:Date:

Signature of Entrant:Date:

FOR ENTRY TO BE CORRECT, PLEASE ENSURE SIGNATURES ARE COMPLETED PRIOR TO POSTING

Note: If Driver and Entrant are the same, only one signature is required to cover the (1) Indemnity, (2 & 3) Declarations and (4) Consent

POST THIS ENTRY TO: The Secretary
MRDC
Kevin Sweeney
11 Beaumaris Place
Dinsdale
Hamilton 3204.....

Please make cheques payable to:
Mini Racing Drivers Club Inc
Or
Direct credit to MRDC ASB Account;
0123077 0361596 00