

# ROLL PROTECTION HOMOLOGATION APPLICATION

**NOTE: Payment must accompany this application. DO NOT SEND CASH VIA POST (GST Inc)**

**Standard Processing (First 6 vehicles): \$900.00 Additional vehicles \$75.00 each**

**Applicant:** \_\_\_\_\_

WHEN PAYING BY CREDIT CARD: Please debit my VISA / MASTERCARD	
Card No	Expires
Name of Card Holder	
Signed	Date

- Submit completed application with the first 6 (min) vehicle logbook application forms**
- SECTION TWO: A CLEAR and ACCURATE** line drawing must be provided.
- SECTION THREE:** The applicant **MUST IDENTIFY** which design prescriptions the roll protection has been constructed to.
- SECTION FOUR:** Detail ALL members of the rollbar/rollcage and reference each member on drawing in Section Two. The material description, material standard, and the material specifications must be provided.
- SECTION FIVE:** Measurements must be provided for the main rollbar and front/lateral rollbar bends reduction (A) and expansion (B) accurate to the nearest 0.1mm. Measurement X is the original outside tube diameter (OD), which must be measured away from the bend.
- SECTION SIX:** Identify the welding method used, the wire/electrode type and size, **the welding technicians' name, qualifications, and company.**
- SECTION SEVEN:** Provide the actual measurements of the safety cage as viewed through the door opening. The minimum/maximum dimensions are detailed in the chart. Additionally, confirm that in frontal projection, any reinforcement of bends and junctions of the upper corners of the front rollcage are contained within the shaded area of the drawing.
- SECTION EIGHT:** Details of the material, thickness and area of the Reinforcement Plate must be supplied. If rollbar leg Footings or Footing Boxes are incorporated in the design, full details of these are also required. When the roll protection is removable, (ie. when the rollbar footing plates are bolted to the reinforcement plates that are welded to the vehicle structure), full details of these fasteners are required in Section Nine.
- SECTION NINE:** Only demountable joints as authorised by FIA Appendix J or Schedule A are acceptable. Please note the restricted use of some joint types (e.g. hinge type, directional load type etc). All joint types, fasteners and locking methods must be detailed.
- SECTION TEN:** Approval of an existing (un-homologated) structure is only possible under Schedule A (for National competitions). Contact the MotorSport NZ office to organise an inspection by a Technical Officer or Technical Advisor where appropriate.
- SECTION ELEVEN: Declaration 1** – Required to be completed by the manufacturer of the roll protection and sign accordingly to confirm that the safety structure has been designed, constructed and installed in compliance with the applicable regulations.  
**Declaration 2** – is required where the material is purchased as a 'Appendix J Kit-Set' hence **MUST** be installed by a MotorSport NZ recognised installer (who shall complete the declaration accordingly).  
**Declaration 3** – shall be completed by the NZ supplier of the 'Appendix J Kit-Set'.
- SECTION TWELVE:** All applicable photographs **MUST** be supplied of the **UN-PAINTED** structure and **MUST** be **CLEAR and CLOSE-UP** views. **NOTE:** Quality digital photos are accepted either burned to a CD or e-mailed to [technical@motorsport.org.nz](mailto:technical@motorsport.org.nz)

## FOR SCHEDULE A DESIGN COMPLIANCE ONLY

These drawings may be used as the *basis* of your line drawing for SECTION TWO  
Accurately and clearly draw-in all the rollbar / rollcage members incorporated in the design

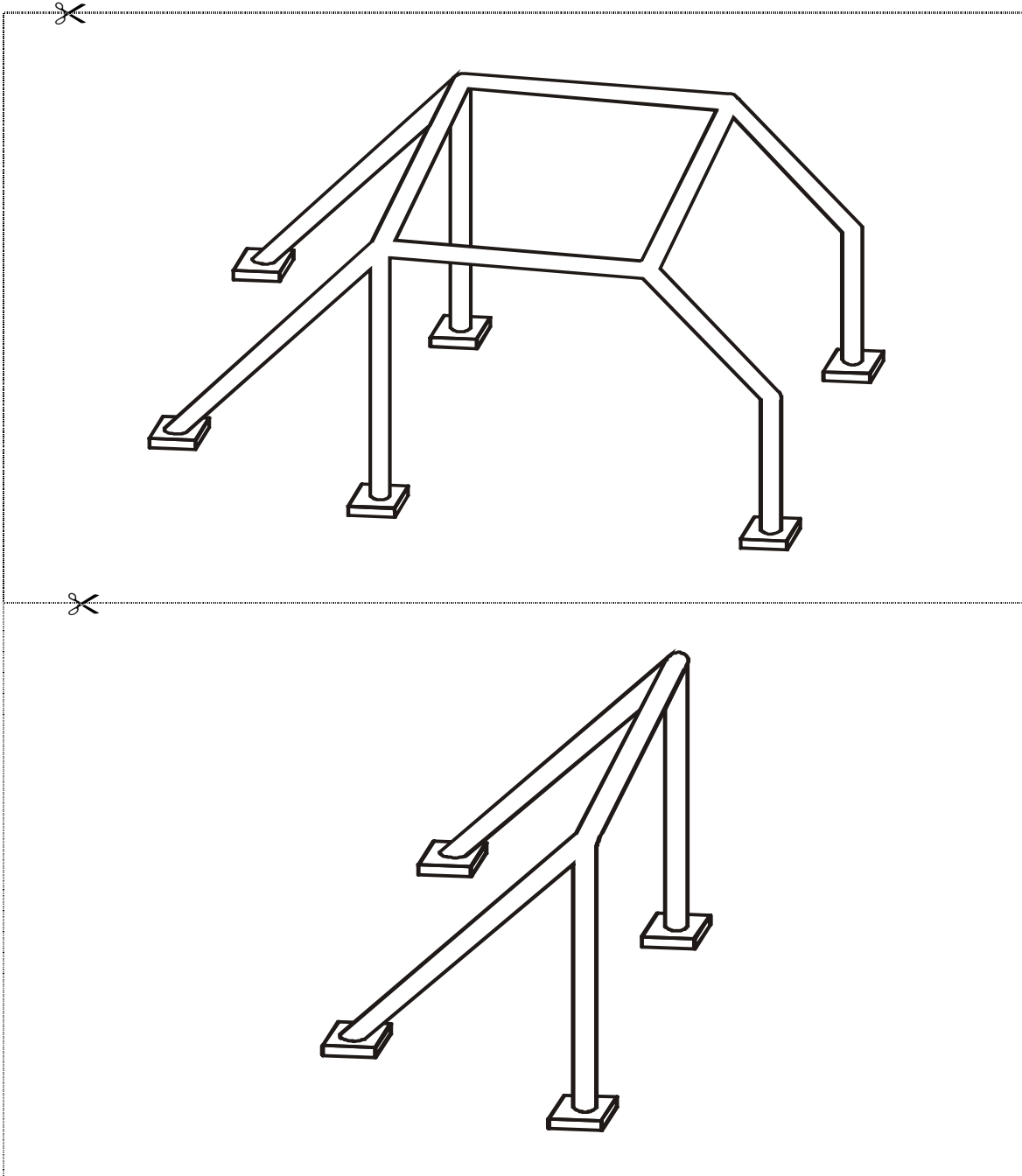

Representing the



Homologation Number and Approval Date:

**NZTA** \_ \_ \_ / \_ / \_ \_ \_

Approval Date:

FIA Homologation #

MSNZ Logbook:

FOR OFFICE USE ONLY

# ROLL PROTECTION TYPE APPROVAL HOMOLOGATION APPLICATION

Not Valid for INTERNATIONAL COMPETITIONS

Application Date: \_ \_ / \_ \_ / \_ \_ \_ \_

Application Prepared by: \_ \_ \_ \_ \_

## SECTION ONE – VEHICLE / OWNER DETAILS

Manufacturer: \_ \_ \_ \_ \_ Model: \_ \_ \_ \_ \_ Yr of Manufacture: \_ \_

Registration No: \_ \_ \_ \_ \_ Vehicle Chassis #: \_ \_ \_ \_ \_

Owner: \_ \_ \_ \_ \_ Postal Address: \_ \_ \_ \_ \_ Phone: \_ \_ \_ \_ \_

## SECTION TWO – ROLLBAR / ROLLAGE DRAWING (line drawing of actual structure)

Drawing to be accurate representation of actual structure installed in vehicle clearly detailing ALL members. Number each member (Ref. Section Four)

## SECTION THREE – ROLL PROTECTION DESIGN COMPLIANCE

The rollbar / rollage as described herein has been designed, fabricated and installed in the vehicle detailed above in accordance with the specified requirements of (*tick box as appropriate*);

**NATIONAL COMPETITONS:** MotorSport NZ - Appendix Two, Schedule A - Article 4.4.

**INTERNATIONAL COMPETITONS:** FIA Appendix J

*This certificate is only valid once each page bears a MotorSport NZ official RED stamp*

**SECTION FOUR – MATERIAL SPECIFICATION**

**NOTE:** Member numbers to reference SECTION TWO drawing

Member number	Member name	Material Description / Standard	Outside Diameter (mm)	Wall Thickness (mm)	Tensile Strength (MPa)
1.	Main Hoop				
2.	Backstays				
3.	Diagonals				
4.	Lateral / Front rollbar				
5.	Safety Harness Bars				
6.	Other (specify)				
7.					
8.					
9.					
10.					
11.					
12.					
13.					
14.					
15.					
16.					

**SECTION FIVE – MATERIAL BEND MEASUREMENTS**

	Main Rollbar	Lateral Rollbar
<b>Original Size:</b>	X =      mm	X =      mm
<b>Reduction:</b>	A =      mm	A =      mm
<b>Expansion:</b>	B =      mm	B =      mm
<b>Calculation:</b>	A ÷ B =	A ÷ B =

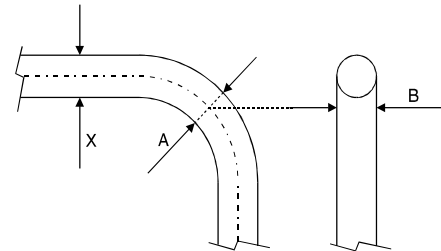

**SECTION SIX – WELDING DETAILS**

<b>Primary Welding Method:</b>	<input type="checkbox"/> MIG	<input type="checkbox"/> TIG
<b>Wire Type &amp; Size:</b>		
<b>Welding Technicians' Name:</b>		
<b>Company:</b>		
<b>Technicians' Qualifications:</b>		
<input type="checkbox"/>	<b>All joins fully welded through 360° (Tick box)</b>	

*This certificate is only valid once each page bears a MotorSport NZ official RED stamp*

**SECTION SEVEN – POSITION OF MEMBERS IN DOOR / WINDSCREEN APERTURES**

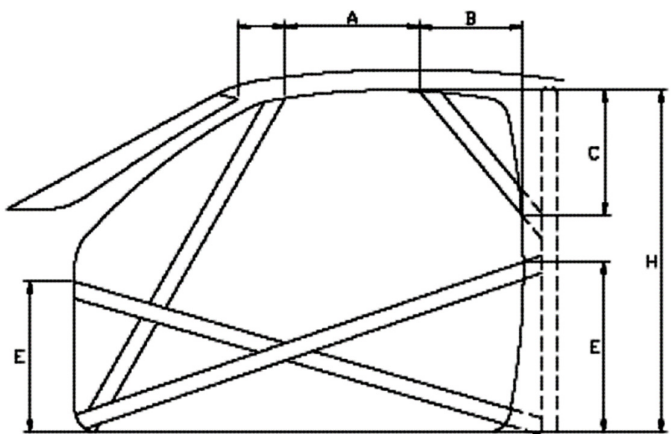

Door aperture - complete as applicable to design	
A = 300mm MIN	Actual = <span style="border-bottom: 1px solid black; display: inline-block; width: 50px;"></span> 100 mm in vertical projection mm
B = 250mm MAX	Actual = <span style="border-bottom: 1px solid black; display: inline-block; width: 50px;"></span> mm
C = 300mm MAX	Actual = <span style="border-bottom: 1px solid black; display: inline-block; width: 50px;"></span> mm
E = Less than 1/2 R100 mm	Actual = <span style="border-bottom: 1px solid black; display: inline-block; width: 50px;"></span> mm
H = (Height of Door)	Actual = <span style="border-bottom: 1px solid black; display: inline-block; width: 50px;"></span> mm

Confirmed that any reinforcement members are contained within shaded area (**Tick box**)

**SECTION EIGHT – ATTACHMENT TO BODYSHELL / CHASSIS**

	Main rollbar	Lateral / Front rollbar	Backstays
<b>Reinforcement Plate</b> (being plate welded to bodyshell)	Material: Thickness: mm Area: cm <sup>2</sup>	Material: Thickness: mm Area: cm <sup>2</sup>	Material: Thickness: mm Area: cm <sup>2</sup>
<b>Footing Box</b> (being the box welded to reinforcement plate)	Material: Thickness: mm Area: cm <sup>2</sup>	Material: Thickness: mm Area: cm <sup>2</sup>	Material: Thickness: mm Area: cm <sup>2</sup>

*This certificate is only valid once each page bears a MotorSport NZ official RED stamp*

**SECTION NINE – REMOVABLE MEMBERS / FASTENERS**

**None Fitted (Tick box where applicable)**

Tick boxes as appropriate	Removable members fitted (as follows):		Joint Drawing No. (from MotorSport Manual)	Photograph No. (from Section Eleven)
	<input type="checkbox"/>	Backstays to main rollbar		
	<input type="checkbox"/>	Lateral rollbar to main rollbar		
	<input type="checkbox"/>	Connecting members		
	<input type="checkbox"/>	Diagonal members		
	<input type="checkbox"/>	Side intrusion members		
	<input type="checkbox"/>	Other (specify)		
	<input type="checkbox"/>			

Member	Fastener Type	Number Fitted	Size	Grade	Locking Method

**SECTION TEN – INSPECTION BY TECHNICAL OFFICER (ONLY COMPLETE IF DIRECTED)**

**Section Ten is ONLY applicable to Schedule A homologation applications** for roll protection structures not previously homologated by MotorSport NZ, where the manufacturer is unknown and/or construction data is unavailable to complete the application in full. Please note that this inspection report is not a guarantee of homologation acceptance.

**To be completed by Technical Officer / Technical Advisor only**

I have inspected the structure fitted to the vehicle detailed in Section One of this application and confirm that:

- The construction / design is in compliance with the specifications of Schedule A; and
- The structure has been professionally constructed and is in an acceptable condition; and
- The structure design does not impede the operation of any mandatory controls; and
- The structure design does not unreasonably hinder the entry and/or exit of the vehicle; and
- Clear, close-up pictures of the specified areas of the UN-PAINTED structure are provided; and
- (if fitted) any demountable joints / fasteners are correctly located and of an approved type and strength.

**Safety Cages previously homologated by an overseas ASN (with accompanying ASN documentation)**

I have inspected the safety cage and the documentation provided relative to the vehicle detailed in Section One of this application and confirm that:

The construction / design is as per the documentation and the structure is in an acceptable condition

In addition, I make the following comments:

Name:

Signature:

Licence #:

*This certificate is only valid once each page bears a MotorSport NZ official RED stamp*

**SECTION ELEVEN – DECLARATIONS**

Choose either **DECLARATION 1** or **DECLARATIONS 2 & 3** and complete in full.

<b>1 - DECLARATION BY MANUFACTURER</b>
<b>For all applications EXCEPT 'Appendix J Kit-Set' safety cages</b>
Company Name: _____ Phone No.: _____ E-mail: _____ Physical Address: _____ _____
I hereby declare that the rollbar/rollcage, as detailed in this application, has been manufactured and installed in total conformity with the specified requirements of Schedule A – Article 4.4 / FIA Appendix J ( <i>delete as applicable</i> ).  Name: _____ Position in Company: _____ Signature: _____ <b>Qualifications:</b> _____

<b>2 - DECLARATION BY RECOGNISED APPENDIX J COMPLIANT KIT-SET SAFETY CAGE INSTALLER</b>
<b>Only applicable where the structure has been purchased as a 'Appendix J Kit-Set'</b>
I the undersigned, hereby declare that the kit-set safety cage as supplied by the company detailed below has been installed in accordance with the exacting requirements of the installation instructions supplied with the kit-set and the requirements of Schedule A and/or Appendix J Article 253-8.4.  Installers Company Name: _____ E-mail: _____ Physical Address: _____ Name: _____ Position in Company: _____ Signature: _____ <b>Qualifications:</b> _____
<b>Welding Technicians' Name and Qualifications:</b> _____

<b>2.1 - DECLARATION BY NZ SUPPLIER OF APPENDIX J KIT-SET SAFETY CAGE</b>
Suppliers' Company Name: _____ Phone No.: _____ I the undersigned declare that this 'kit-set' safety cage as manufactured by _____ has been sold on the understanding that it will be installed by a MotorSport NZ recognised installer.  Name: _____ Position in Company: _____ Signature: _____

*This certificate is only valid once each page bears a MotorSport NZ official RED stamp*

**SECTION TWELVE – PHOTOGRAPHS**

**MAIN ROLLBAR - TOP BEND DETAIL**

*MANDATORY PHOTOGRAPH*

**All photographs of UNPAINTED structure MUST BE CLEAR and CLOSE-UP.**

**LATERAL / FRONT ROLLBAR - TOP BEND DETAIL**

*MANDATORY PHOTOGRAPH*

**All photographs of UNPAINTED structure MUST BE CLEAR and CLOSE-UP.**

*This certificate is only valid once each page bears a MotorSport NZ official RED stamp*



**SECTION TWELVE – PHOTOGRAPHS (continued)**

**MAIN ROLLBAR LEG - ATTACHMENT DETAIL TO FLOORPAN / CHASSIS**

*MANDATORY PHOTOGRAPH*

**All photographs of UNPAINTED structure MUST BE CLEAR and CLOSE-UP.**

**LATERAL / FRONT ROLLBAR LEG - ATTACHMENT DETAIL TO FLOORPAN / CHASSIS**

*MANDATORY PHOTOGRAPH*

**All photographs of UNPAINTED structure MUST BE CLEAR and CLOSE-UP.**

*This certificate is only valid once each page bears a MotorSport NZ official RED stamp*

**SECTION TWELVE – PHOTOGRAPHS (continued)**

**BACKSTAY - LOWER ATTACHMENT DETAIL TO FLOORPAN / CHASSIS**

*MANDATORY PHOTOGRAPH*

**All photographs of UNPAINTED structure MUST BE CLEAR and CLOSE-UP.**

**'B' POST - ATTACHMENT DETAIL**

*WHERE NO PHOTOGRAPH IS ATTACHED IT WILL BE ACCEPTED THAT  
THERE IS NO 'B' POST ATTACHMENT*

**All photographs of UNPAINTED structure MUST BE CLEAR and CLOSE-UP.**

*This certificate is only valid once each page bears a MotorSport NZ official RED stamp*

**SECTION TWELVE – PHOTOGRAPHS (continued)**

**SAFETY HARNESS - ATTACHMENT DETAIL TO ROLL PROTECTION MEMBER/S**

*PHOTOGRAPH/S REQUIRED OF ALL HARNESS ATTACHMENT  
POINTS TO ROLLBAR / ROLLCAGE MEMBERS*

**All photographs of UNPAINTED structure MUST BE CLEAR and CLOSE-UP.**

**SIDE VIEW OF FRONT DOOR OPENING (refer Drawing No. 253-17D)**

*MANDATORY PHOTOGRAPH FOR  
ALL ROLLCAGE DESIGNS*

**All photographs of UNPAINTED structure MUST BE CLEAR and CLOSE-UP.**

*This certificate is only valid once each page bears a MotorSport NZ official RED stamp*

**SECTION TWELVE – PHOTOGRAPHS (continued)**

**FRONT VIEW THROUGH WINDSCREEN (refer Drawing No. 253-17E)**

*MANDATORY PHOTOGRAPH FOR  
ALL ROLL CAGE DESIGNS*

**All photographs of UNPAINTED structure MUST BE CLEAR and CLOSE-UP.**

**COMPETITION SEAT MOUNTING RAILS (when attached to safety cage)**

*WHERE NO PHOTOGRAPH IS ATTACHED IT WILL BE ACCEPTED THAT THERE ARE  
NO SEAT MOUNTING RAILS ATTACHED TO THE SAFETY CAGE*

**All photographs of UNPAINTED structure MUST BE CLEAR and CLOSE-UP.**

*This certificate is only valid once each page bears a MotorSport NZ official RED stamp*

**SECTION TWELVE – PHOTOGRAPHS (continued)**

**REMOVABLE MEMBER – JOINT DETAIL (1)**

*WHERE NO PHOTOGRAPH IS ATTACHED IT WILL BE ACCEPTED THAT THERE ARE NO  
REMOVABLE MEMBERS*

**All photographs of UNPAINTED structure MUST BE CLEAR and CLOSE-UP.**

**REMOVABLE MEMBER – JOINT DETAIL (2)**

*WHERE NO PHOTOGRAPH IS ATTACHED IT WILL  
BE ACCEPTED THAT THERE ARE NO  
REMOVABLE MEMBERS*

**All photographs of UNPAINTED structure MUST BE CLEAR and CLOSE-UP.**

*This certificate is only valid once each page bears a MotorSport NZ official RED stamp*