

## **2020 Championship Race Series**

### **2020 MSNZ Castrol Toyota Racing Series Schedule TRS Technical Amendment**

*This amendment is issued under the provisions of the MotorSport NZ National Sporting Code Article 18(2) in confirmation that the following amendments, notices or points of clarification have been authorised to the text of the Supplementary Regulations of the above-named event. It is recommended that in addition to retaining a copy of this bulletin all parties modify the text of the regulations according to the following:*

---

#### **Schedule TRS Amendment:**

- 1. Amend Article 4.14 Main Dimensions as stated in the schedule below.**
  - 2. Amend Article 11.6 UMP Adjustment as stated in the schedule below.**
- 

#### **ITEM 1:**

- 1. 4.14 (4)** All measurements of height shall be made with the Car in Race Trim and with the driver on board seated in the normal driving position. If failure occurs a re-measurement will be performed with a nominated set of new tyres provided by the TRS Championship Scrutineer and set at the manufacturer's recommended cold pressure of ~~21.0 PSI~~ **20.0 PSI**. This Set of Tyres will be available for Competitors to use throughout the Meeting to check their ride height.

**Reason:** *To align the reference tyre pressure for ride height checks closer to actual post session tyre pressure.*

---

**ITEM 2:**

2. Replace the existing Schedule TRS 11.6 text and include the additional diagram below:

**11.6** The It is **only** permitted to use both the Standard Position UMP adjustment and the -5 Position UMP adjustment as defined by the diagram 11.6 below.

Diagram 11.6

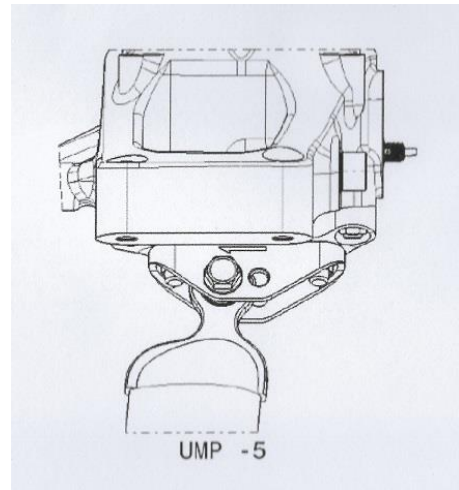
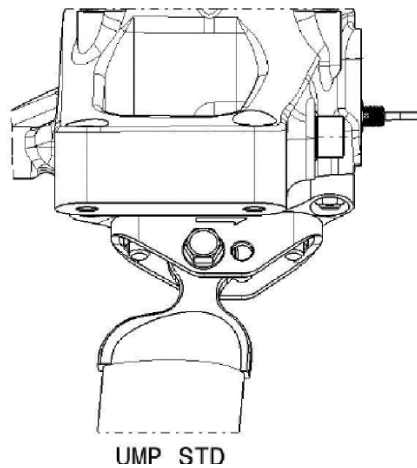

**Reason:** To provide for range of adjustment.

---

This bulletin is issued by MotorSport NZ  
Bulletin authorised by:

A handwritten signature in black ink, appearing to read "Elton Goonan".

Elton Goonan  
MotorSport New Zealand

