

SAFETY CAGE / ROLLBAR HOMOLOGATION APPLICATION Technical Form T002

IMPORTANT INFORMATION ABOUT THIS APPLICATION

ALL APPLICANTS MUST READ THIS IMPORTANT INFORMATION AND MUST FOLLOW THE REQUIREMENTS OF THIS APPLICATION OR IT MAY BE RETURNED AND AN ADDITIONAL 50% OF THE ORIGINAL FEE CHARGED

If you require help / assistance in completing this application please refer to the 'Guidelines for Safety Cage Homologation' available on the MSNZ website or phone the Technical Department for assistance.

Once complete forward original documents either by Courier to physical address or Mail to PO Box as above.

- MSNZ Vehicle Logbook:** A valid logbook or logbook application (Form T001) **MUST** accompany this application.
- Instruction 1 (Section 1):** Complete **ALL** vehicle details and ensure manufacturers' Chassis No. is correct. Registration No. is only applicable for road registered vehicles.
- Instruction 2 (Section 2 & 9):** In Section 2 complete Constructor details and in Section 9 the appropriate Declaration **MUST** be completed and signed. **Declaration 1** is solely for MSNZ Recognised Safety Cage Manufacturers. **Declaration 2** is for all other individuals constructing Schedule A compliant safety structures. Homologation certification **cannot** be issued when a false declaration is made hence it is imperative that the signatory is fully conversant with the stated regulations and is suitably qualified to make the declaration.
- Instruction 3 (Section 3):** A **CLEAR** and **ACCURATE** line drawing of the structure must be provided detailing **ALL** the tube members which **MUST** be individually numbered and referenced in Section 4.
- Instruction 4 (Section 4):** All tube members of the structure **MUST** be detailed here. If multiple members are fitted (e.g. 2x lateral rollbar, reinforcements etc) they only need detailing once provided they have the same number in section 3 drawing. Only tube manufactured to the MSNZ standard – steel tubes for safety cages is authorised (excepting Recognised Manufacturers). Material specifications should be stated as per the material 'specification sheet' available from the material supplier.
- Instruction 5 (Section 5):** Measurements of the main rollbar and front/lateral rollbar top bends; reduction (A) and expansion (B) must be accurate to the nearest 0.1mm. Measurements should be performed at the centre of the bend radius and prior to welding in other members.
- Instruction 6 (Section 6):** The welding technician **MUST** be an accomplished trade's person with trade qualifications and/or proven/trade experience. The welding declaration **MUST** be ticked to confirm that all joins of the principle structure are welded through 360°.
- Instruction 7 (Section 7):** A reinforcement plate welded to the bodysell is **mandatory** for each lower attachment point of the main & lateral/front rollbars and the backstays – material and measurements must be provided. The minimum area is that in full contact with the bodysell / chassis. A footing box may also be incorporated in the design, mounted on top of the reinforcement plate – material and measurements must be provided. In the case of removable structures a footing plate is required welded to the rollbars and in turn bolted to the reinforcement plate and all fastener specifications must be provided.
- Instruction 8 (Section 8):** Provide the actual measurements of the safety cage as viewed through the door opening. Confirm that in frontal projection, the front/lateral rollbar and any reinforcement members are contained within the shaded area of the drawing.
- Photographs:** All applicable photographs **MUST** be included with this application. All photographs **MUST** be of the **UN-PAINTED** structure and **MUST** be **CLEAR and CLOSE-UP** views. Hi resolution digital photos are preferable (clearly identifying applicants name and vehicle details) either on CD or by e-mail to technical@motorsport.org.nz

You can submit your application via MotorSport Online! To request log in details for an existing record or to register please go to <https://online.motorsport.org.nz/>

Please note that manual applications will take longer to process than applications submitted via the online system.

PAYMENT BY CREDIT CARD: Please debit my VISA / MASTERCARD	
Card No	Expires
Name of Card Holder	
Signed	Date
<input type="checkbox"/> Standard Processing: \$250.00 <input type="checkbox"/> Priority Processing + \$125.00 (\$375.00 total)	
Payments can be made by Internet Banking to: ASB Bank 12-3192-0017344-00 Cheque Payments can be made out to MotorSport New Zealand (Please reference Name and Application Type)	
GST No. 10-062-349	Payment Details- Fee's Effective as of 01 Oct 2014



Affiliated to the FIA

OFFICE USE ONLY

Date Received: _____

Date Approved: _____

Logbook Number: _____

NZ

MotorSport NZ Inc
69 Hutt Road, Thorndon
PO Box 3793
Wellington 6015
Ph: 04 815 8015
Fax: 04 472 9011
Web: motorsport.org.nz

SAFETY CAGE / ROLLBAR CERTIFICATE

In compliance with MotorSport New Zealand Homologation Regulations for Safety Cages
Appendix Two Schedule A – Part One Article 4.6 and Part Two Article 5 of the current MotorSport NZ Manual

This certificate is valid for all National competitions for the structure bearing the above homologation number
[Note: Form T002-FIA must be used to certify safety structures for International Competitions]

SECTION 1- VEHICLE DETAILS *(Refer Instruction 1)*

Vehicle Make: _____ Vehicle Model: _____ Year: _____

Vehicle Chassis No.: _____ Registration No.: _____

SECTION 2- SAFETY CAGE CONSTRUCTOR DETAILS

Constructor Name: _____

Postal Address: _____

Email Address: _____ Daytime Phone #: _____

SECTION 3 SAFETY CAGE / ROLLBAR DRAWING *(Refer Instruction 3)*

*This certificate is only valid once each page bears a MotorSport NZ official RED stamp
and becomes invalid if the structure is modified in any way from the design shown herein*

SECTION 4- MATERIAL SPECIFICATION (Refer Instruction 4)

Member Number	Member Name	Material Description / Standard	External Diameter (mm)	Wall Thickness (mm)	Tensile Strength (MPa)
Principle structure					
1.	Main Rollbar				
2.	Lateral / Front Rollbar				
3.	Backstays				
4.	Diagonals				
5.	Windscreen Bar				
6.	Safety Harness Bar				
Other members (detail ALL other members)					
7.	Side Intrusion Bars				
8.	Reinforcement Bars				
9.	Forward Extension				
10.					
11.					
12.					
13.					
<input type="checkbox"/> All tube members declared to be the same material standard as detailed above (✓ box)			Note: Forward extensions required when MOPS/SRS is removed on road registered vehicle's		

SECTION 5- MATERIAL BEND MEASUREMENTS (Refer Instruction 5)

	Main Rollbar	Lateral Rollbar
Original Size:	X = mm	X = mm
Reduction:	A = mm	A = mm
Expansion:	B = mm	B = mm
Calculation:	A ÷ B =	A ÷ B =

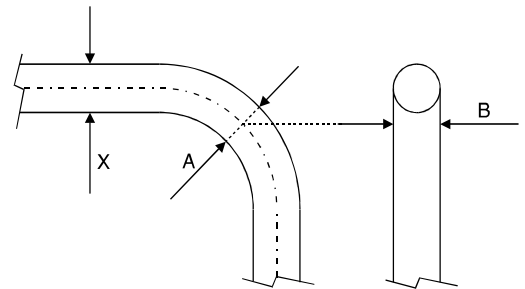

SECTION 6- WELDING DETAILS (Refer Instruction 6)

Primary Welding Method And Declaration: (✓ Box)	<input type="checkbox"/> MIG <input type="checkbox"/> TIG	<input type="checkbox"/> ALL JOINS WELDED THROUGH 360°
Welding Technicians' Name: Technicians' Qualifications:		

This certificate is only valid once each page bears a MotorSport NZ official RED stamp and becomes invalid if the structure is modified in any way from the design shown herein

SECTION 7- ATTACHMENT TO BODYSHELL / CHASSIS (Refer Instruction 7)

	Main rollbar	Lateral / Front rollbar	Backstays
Welded structures			
Reinforcement Plate (mandatory plate that is welded to bodyshell)	Material:	Material:	Material:
	Thickness: mm	Thickness: mm	Thickness: mm
	Area: cm ²	Area: cm ²	Area: cm ²
	Footing Box (being optional fabricated 'box' welded directly to the reinforcement plate)	Material:	Material:
	Thickness: mm	Thickness: mm	Thickness: mm
	Area: cm ²	Area: cm ²	Area: cm ²
Removable structures			
Footing Plate (optional plate welded to rollbar and bolted to the reinforcement plate)	Material:	Material:	Material:
	Thickness: mm	Thickness: mm	Thickness: mm
	Area: cm ²	Area: cm ²	Area: cm ²
Attachment details (bolts / nuts minimum grade ISO 8.8)	Bolt size:	Bolt size:	Bolt size:
	Bolt grade:	Bolt grade:	Bolt grade:
	Locking method:	Locking method:	Locking method:

Note: Any demountable joints to be detailed on separate sheet

SECTION 8- POSITION OF MEMBERS IN WINDSCREEN / DOOR APERTURES (Refer Instruction 8)

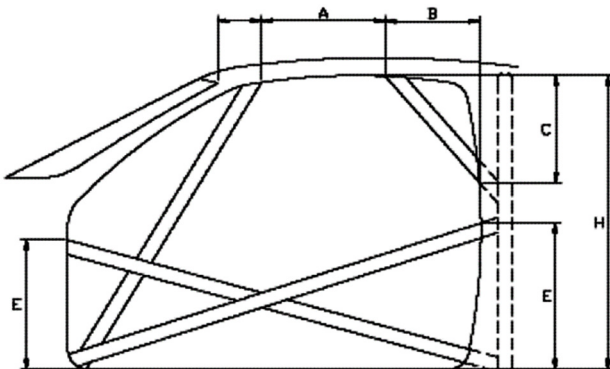
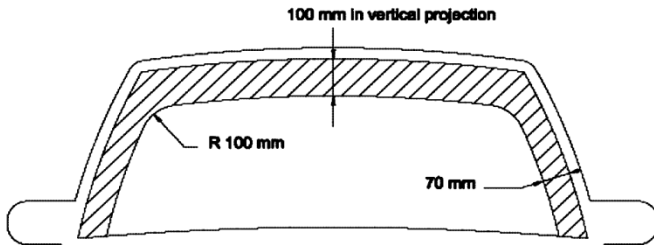

Windscreen aperture	
<input type="checkbox"/> Confirmed that any reinforcement members are contained within shaded area (✓ box)	
Door aperture	
A = 300mm MIN	Actual = mm
B = 250mm MAX	Actual = mm
C = 300mm MAX	Actual = mm
E (front) = (Less than ½ H)	Actual = mm
E (rear) = (Less than ½ H)	Actual = mm
H = (Height of Door)	Actual = mm

This certificate is only valid once each page bears a MotorSport NZ official RED stamp and becomes invalid if the structure is modified in any way from the design shown herein

SECTION 9- DECLARATIONS

1 - DECLARATION BY MSNZ RECOGNISED MANUFACTURER

On behalf of the company named below I hereby declare that the structure as detailed in this application has been designed, fabricated and installed in total conformity with the current specified requirements of MSNZ Appendix Two, Schedule A Part One Article 4.6 and Part Two Article 5 or as approved in writing by the MSNZ Technical Department.

Company Name: _____ MSNZ Recognition No.: **RM** _____

Signatory Name: _____ Position Held: _____

Signature: _____

Alternative design / material specification approved through calculation report or demonstrated qualifications

Name of Company / Engineer: _____

Report No.: _____

2 - DECLARATION BY CONSTRUCTOR

I hereby declare that I have read and understood the requirements of this certification and that the structure as detailed in this application has been designed, fabricated and installed in total conformity with the current specified requirements of MSNZ Appendix Two, Schedule A Part One Article 4.6 and Part Two Article 5.

Name: _____ Signature: _____

Qualification / Experience: _____

Postal Address: _____

Email Address: _____ Phone #: _____

INSPECTION REPORT (FOR OFFICIAL USE ONLY)

An inspection report is ONLY required when a physical inspection is requested by the MSNZ Technical Dept

- Safety Cage previously homologated by an overseas ASN
- The construction / design is in compliance with the specifications of Schedule A or FIA Appendix J
- The tube used is identified as meeting the size and strength requirements of Schedule A
- The structure has been professionally constructed and is in an acceptable condition
- The structure design does not unreasonably hinder the entry and/or exit of the vehicle
- Clear, close-up pictures of the specified areas of the structure are provided
- (if fitted) any demountable joints / fasteners are correctly located and of an approved type and strength.
- Other;

Name: _____ MSNZ Officials Licence No.: _____

Signature: _____ Dated: _____ Acceptance stamp: _____

This certificate is only valid once each page bears a MotorSport NZ official RED stamp and becomes invalid if the structure is modified in any way from the design shown herein

PHOTOGRAPHS

The following photographs must be presented with this application

Refer Note	PICTURE DETAIL REQUIRED	✓ Confirmed photo included
1	General view showing rearwards members	
2	General view showing forward members	
3	Main rollbar top bend	
4	Lateral / Front rollbar top bend	
5	Main rollbar attachment detail to floorpan	
6	Lateral / Front rollbar attachment detail to floorpan	
7	Backstay attachment detail to floorpan	
8	Safety Harness bar attachment detail to other members	
9	View of complete drivers door opening	
10	View through front windscreen	
11	Forward Extension (if applicable)	

All photographs **MUST** be of the **UN-PAINTED** structure and **MUST** be **CLEAR** therefore in focus to clearly show the detail of the structure.

Hi resolution digital photos are preferable presented on a CD with the application or submitted by e-mail to technical@motorsport.org.nz

CLEARLY MARK CD OR E-MAIL WITH APPLICANTS NAME AND VEHICLE DETAILS.

Printed photographs may also be accepted (9cm x 13cm print size) included with the application

Only send necessary photos as noted below- If additional photos are required they will be requested

Photograph Notes;

- 1) General view of rear half of structure taken through door opening
- 2) General view of front half of structure taken through door opening
- 3) Close-up view of main rollbar top bend detail and member welding
- 4) Close-up view of lateral/front rollbar top bend detail and member welding
- 5) & 6) Close-up view of rollbar attachment to reinforcement plate
- 7) Close-up view of backstay attachment to reinforcement plate
- 8) General view of harness bar and its attachment to safety cage structure
- 9) View of complete door opening (taken from outside of vehicle - door open wide)
- 10) Clear view looking into front windscreen (taken standing in front of bonnet in drivers line of sight). Do not use flash!

DRAWINGS

These line drawings may be used as the *basis* of the drawing

(Do not use for complex designs)

Accurately and clearly draw-in all other tube members of your actual Safety Cage / Rollbar design.

